



OULUN YLIOPISTO
UNIVERSITY of OULU

Dept. of Process and Environmental Engineering

Master's Thesis

Municipal solid waste management (MSWM) in sparsely populated Northern areas:

Developing an MSWM strategy for the city of Kostomuksha, Russian Federation

Oulu, May 23.5.2012

Author

Sari Piippo, D.Sc.

Supervisor

Eva Pongrácz, Docent, D.Sc.

Advisor

Paula Saavalainen, M.Sc.

Advisor

Juhani Kaakinen, M.Sc.

Department		Unit	
Dept. of Process and Environmental Engineering		Thule Institute, NorTech Oulu	
Author		Supervisor	
Sari Piippo		Eva Pongrácz, D.Sc.(Tech)	
Name of the thesis			
Municipal solid waste management (MSWM) in sparsely populated Northern areas: Developing an MSWM strategy for the city of Kostomuksha, Russian Federation			
Subject	Level of studies	Date	Number of pages
Environmental Engineering	Master's Thesis	May 2012	110 p, 12 appendices
Abstract			
<p>Municipal solid waste (MSW) means wastes produced in households, trade, industries, public and private institutes, which are handled in the municipal solid waste management (MSWM) system. EU legislation requires Member States to compile waste management plans which follow relevant EU directives. Strategic planning is necessary in order for MSWM services to meet demand, be suitable to needs and cost-effective. The strategic MSWM planning process consists of six phases: general considerations, status part, planning part, consultation process, implementation and plan revision. To achieve a reasonable and well-functioning MSWM system, the principles of sustainable development, integrated solid waste management and the waste management hierarchy must be included and practiced.</p> <p>The aim of this work was to study MSWM strategies for sparsely populated Northern areas and to propose an MSWM strategy for the city of Kostomuksha in the Republic of Karelia, Russian Federation. To achieve a sustainable MSWM system in sparsely populated Northern areas, characterized by low waste volumes and long transportation distances, is challenging. The example of the city of Oulu, the largest city in Northern Finland is presented, which has a well-organized MSWM system. Conversely, Lapland, the most sparsely populated area of Finland, still faces many challenges in its MSWM systems. In the Russian Federation, there was no information about well-functioning Russian MSWM system. Recovery and recycling rates are low, and there is no MSW recovery infrastructure in the Republic of Karelia.</p> <p>Using the information on prevalent MSW amounts in Kostomuksha, present and future amounts of waste fractions were estimated and scenarios on the recovery and utilization of these waste fractions were presented. It was concluded that the best option would be to separately collect bio-waste at kerbside and treat in an anaerobic digester. Other major recoverable fractions (paper and cardboard, plastic, metal and glass) would be reasonable to collect in centralized collection points and transfer to utilization facilities through transfer stations. In order to implement this plan, it is essential to have recipient facilities in a reasonable distance and an infrastructure of transfer stations built in the Republic of Karelia. This will require regional level legislative control and political agreement in the Republic of Karelia. On the municipal level, also information and education campaigns will need to be planned in order for the public to get involved and participate in separate waste collection.</p> <p>This work was done as a part of the Green Cities and Settlements (GREENSETTLE) project, co-funded by the European Union, the Russian Federation and the Republic of Finland. It is expected that this thesis will provide information on sustainable MSWM planning to all project partners in the Republic of Karelia.</p>			
Library location			
University of Oulu, Science Library Tellus			
Additional information			

Osasto		Yksikkö	
Prosessi- ja ympäristötekniikan osasto		Thule-instituutti, NorTech Oulu	
Tekijä		Työn valvoja	
Sari Piippo		TkT Eva Pongrácz	
Työn nimi			
Yhdyskuntajätehuolto pohjoisilla harvaanasutuilla alueilla: Yhdyskuntajätehuoltostrategian kehittäminen Venäjän Kostamuksen kaupungille			
Oppiaine	Työn laji	Aika	Sivumäärä
Ympäristötekniikka	Diplomityö	2012 toukokuu	110 s, 12 liitelehteä
Tiivistelmä			
<p>Yhdyskuntajätteellä tarkoitetaan yhdyskuntajätehuollon piirissä käsiteltäviä jätteitä, joita tuotetaan kotitalouksissa, kaupan alalla, teollisuudessa sekä julkisissa ja yksityisissä laitoksissa. EU:n lainsäädäntö vaatii jäsenvaltioitaan laatimaan jätehuoltosuunnitelmia, jotka noudattavat EU:n direktiivejä. Strateginen suunnittelu on välttämätöntä, jotta yhdyskuntajätehuolto vastaa kysyntään, on tarkoituksenmukaista ja kustannustehokasta. Strateginen jätehuoltosuunnittelu koostuu kuudesta osasta: Yleisistä näkökohdista, tilannetarkastelusta, suunnitteluvaiheesta, konsultaatioprosessista, suunnitelman toteutuksesta ja uudelleentarkastelusta. Jotta yhdyskuntajätehuolto olisi hyvintoimivaa ja järkevää, kestävä kehityksen, integroidun yhdyskuntajätehuollon ja jätehierarkian periaatteet tulisi kuulua noudatettavaan suunnitelmaan.</p> <p>Tämän työn tavoitteena oli perehtyä pohjoisten harvaanasuttujen alueiden yhdyskuntajätehuoltostrategioihin ja ehdottaa vastaavaa menetelmää Kostamuksen kaupungille Venäjän Karjalan tasavallassa. Pohjoisten harvaanasuttujen alueiden jätehuollon järjestäminen on haastavaa pienten yhdyskuntajätämäärien ja pitkien etäisyyksien vuoksi. Oulun kaupungin yhdyskuntajätehuolto on hyvin järjestettyä verrattuna erittäin harvaanasuttuun Lappiin. Venäjältä ei ollut saatavissa tietoa toimivasta yhdyskuntajätehuoltotoiminnasta. Lisäksi jätteen hyötykäyttömäärät ovat pieniä eikä Karjalan tasavallan alueella ole yhdyskuntajätteen hyötykäytön infrastruktuuria.</p> <p>Kostamuksen kaupungin nykyisten yhdyskuntajätämäärien perusteella eri hyötyjätäjakeiden nykyisiä ja tulevia määriä arvioitiin, jotta jätteiden hyötykäytölle pystyttiin esittämään erilaisia skenaarioita. Parhain vaihtoehto olisi kerätä biojäte ns. kadunvarsikeräyksenä ja kuljettaa se mädättämöön. Muut suuret hyötyjätäjakeet (paperi, kartonki, metalli ja lasi) tulisi kerätä alueelliseen keräyspisteeseen ja kuljettaa siirtoasemien kautta lopullisiin hyötykäyttökohteisiin. Suunnitelman toteuttamiseen tarvitaan suhteellisen lähellä sijaitsevia hyötyjätettä vastaanottavia laitoksia sekä siirtoasemaverkostoa koko Karjalan alueelle, mikä puolestaan vaatisi lainsäädännöllistä säätelyä ja poliittista yksimielisyyttä Karjalan tasavallan alueella. Kunnallisella tasolla tarvitaan tiedotus- ja koulutuskampanjoita, jotta asukkaat saadaan osallistumaan ja sitoutumaan lajitteluun.</p> <p>Työ on toteutettu osana Vihreät kaupungit ja asuinalueet (GREENSETTLE) -hanketta, jonka rahoittajia ovat olleet Euroopan unionin ENPI-CBC -ohjelma, Venäjän federaatio sekä Suomen tasavalta. On toivottavaa, että projektin partnerit Karjalan tasavallassa voivat hyödyntää työn tuloksia kestävien yhdyskuntajätehuoltostrategioiden kehittämisessä.</p>			
Säilytyspaikka			
Tiedekirjasto Tellus			
Muita tietoja			

Contents

Contents	5
Preface.....	7
Terminology.....	8
1. Introduction.....	9
THEORETICAL PART	11
2. Waste legislation	12
2.1 The Waste Framework Directive.....	12
2.2 Finnish waste legislation	14
3. Municipal solid waste management in EU countries.....	17
4. Municipal solid waste management in Finland.....	23
4.1 Wastes generated in Finland.....	23
4.2 Waste management services in Finland	25
4.2.1 Sorting	26
4.2.2 Collection	26
4.2.3 Transportation	27
4.2.4 Waste treatment.....	28
4.2.5 Landfilling	28
4.3 Recovery rates of wastes in Finland.....	29
4.4 Economic instruments of MSWM in Finland	32
4.4.1 Waste taxes and charges.....	33
4.4.2 Costs of MSWM in households and public services.....	35
4.4.3 Costs of producer responsibility systems	38
4.4.4 Costs of new collection network for packaging material	39
4.4.5 Total costs of waste recovery in Finland.....	41
4.4.6 Prices of recoverables on the European market	42
4.5 MSWM in the sparsely populated Northern areas – case Lapland	44
4.5.1 The prevalent MSWM system.....	44
4.5.2 MSW recovery in Lapland	45
4.6 MSWM in a Northern city - Case Oulu	46
4.6.1 Separate collection of MSW in the city of Oulu	46
4.6.2 The Oulu Waste Management Company	47
4.6.3 Rusko Waste Management Centre	47
4.6.4 Utilization of recoverables collected in Oulu area	50
4.7 Waste management in the future in Finland.....	51
5. Municipal solid waste management in the Russian Federation	53
5.1 Waste recovery	54
5.2 Recoverable waste fractions	55
5.3 Waste treatment.....	56
5.4 Future perspectives.....	57
EXPERIMENTAL PART	59

6. Strategic municipal waste management planning	60
6.1 Identifying key stakeholders and terms of reference.....	65
6.2 Defining the baseline	65
6.3 Establishing the strategic planning framework	67
6.4 Waste Treatment and Disposal	68
6.5 Financial sustainability	69
6.6 Public awareness and participation	70
6.7 Preparing and implementing the plan.....	70
7. Planning of a sustainable MSWM strategy for the city of Kostomuksha	72
7.1 Background part	72
7.2 Status phase	72
7.2.1 Existing situation	72
7.2.2 Estimating MSW amounts in the future	72
7.3 Planning part.....	77
7.3.1 Establishment of an MSW management system	77
7.3.2 Scenarios for the establishment of MSWM system in Kostomuksha	78
The current situation.....	84
Scenario 1 (maximum recovery)	84
Scenario 2 (partial recovery)	87
Scenario 3 (experiences in Finland)	88
Scenario 4 (experiences in Arkhangelsk)	90
Scenario 5 (no recovery at all).....	93
Summary of the Scenarios.....	93
7.4 Implementation part: Conclusions from the Scenarios	96
8. Discussion and conclusions	98
9. References	101
Appendix. 1 Waste legislation in Finland	111
Appendix 2. Producer responsibility organizations in Finland	112
Appendix 3. Surface containers and deep containers	118
Appendix 4. Amounts of wastes under producer responsibility.....	119
Appendix 5. Costs of the establishment of the new collection point network.	120
Appendix 6. Map of Karelia and Finland.	122

Preface

This work has been funded by the Green Cities and Settlements (GREENSETTLE) project, co-funded by the European Union, the Russian Federation and the Republic of Finland. The research work was conducted at the NorTech Oulu unit of Thule Institute, University of Oulu.

First of all, I want to thank my supervisor Eva Pongrácz for guiding me deep into the inspirational world of wastes! Because of her wise advises and excellent support I was able to finish my thesis before the original deadline. I also want to thank my great advisors Paula Saavalainen and Juhani Kaakinen for good comments and meetings, your experiences about waste issues were very valuable to me! Big thanks to my (loud) workmates Ioannis Chamilos, Antonio Caló, Jean-Nicolas Louis, Lauri Mikkonen, Edit Földi and Anni Paukkeri for motivating working environment and many cheerful moments. Special thanks to Niko Hänninen for our incredibly profound conversations during the work days and seminar trips.

Huge thanks to my dearest friends from my (dark) past as a researcher: Riikka, Niina, Anna and Kati for sharing the happy and painful moments of studying (and for having endless lunch and coffee breaks). Especially I want to thank Niina for always having so encouraging and positive attitude and Duracell-Riikka for our really unforgettable years of studying together, and pushing me away from my comfort zone. Thanks to all the other friends and relatives for your support as well!

The greatest and deepest thanks, once again, to my loving family! To my parents: I *really* am planning to stop studying this time (at least for the weekend). To my sisters: Thanks for the mental support and for sharing so many joyful moments of sisterhood! To Jari: Thanks for the patience, for the help, for the support, for teaching me technical mysteries (they still are mysteries...) and for million other things! To Special Little Guys Aapeli and Oskari: Thanks for being there for me!

Oulu, May 2012

Sari Piippo

Terminology used in this work (Directive 2008/98/EC)

"Waste" means any substance or object which the holder discards or intends or is required to discard

"Bio-waste" means biodegradable garden and park waste, food and kitchen waste from households, restaurants, caterers and retail premises and comparable waste from food processing plants

"Waste management" means the collection, transport, recovery and disposal of waste, including the supervision of such operations and the after-care of disposal sites, and including actions taken as a dealer or broker

"Collection" means the gathering of waste, including the preliminary sorting and preliminary storage of waste for the purposes of transport to a waste treatment facility

"Separate collection" means the collection where a waste stream is kept separately by type and nature so as to facilitate a specific treatment

"Prevention" means measures taken before a substance, material or product has become waste

"Re-use" means any operation by which products or components that are not waste are used again for the same purpose for which they were conceived

"Treatment" means recovery or disposal operations, including preparation prior to recovery or disposal

"Recovery" means any operation the principal result of which is waste serving a useful purpose by replacing other materials which would otherwise have been used to fulfil a particular function, or waste being prepared to fulfil that function, in the plant or in the wider economy

"Preparing for re-use" means checking, cleaning or repairing recovery operations, by which products or components of products that have become waste are prepared so that they can be re-used without any other pre-processing

"Recycling" means any recovery operation by which waste materials are reprocessed into products, materials or substances whether for the original or other purposes. It includes the reprocessing of organic material but does not include energy recovery and the reprocessing into materials that are to be used as fuels or for backfilling operations

"Disposal" means any operation which is not recovery even where the operation has as a secondary consequence the reclamation of substances or energy

1. Introduction

Wastes are created in nearly all economic activities. Wastes are considered including all objects or substances which the holder discards, intends to discard, or is legally obliged to discard according to European waste legislation. Waste can be considered an inefficient use of raw materials and, therefore, a loss of resources. Moreover, wastes can contain dangerous substances or have hazardous properties and, therefore, they can pollute the environment and cause health hazards. Also the recovery and processing of wastes can produce emissions. (Finnish environment institute 2011a) Waste management means the collection, transportation, utilization and treatment of waste including the observation of these activities and aftercare of the treatment places. (2008/98/EC)

Municipal solid waste (MSW) usually means all the waste fractions (e.g. kitchen waste, packaging materials, glassware, tin cans) which are handled in the municipal waste management system. MSW is produced in households, trade, industries, construction and public and private institutes. Some part of MSW is composted, recycled or otherwise recovered as material, some of the waste is incinerated or gasified and the rest is landfilled. (Sokka et al. 2007, 478) While waste reduction is the primary objective of any waste legislation, when considering the saving non-renewable resources, the recovery of waste as material or energy is of particular importance. (Finnish environment institute 2011a and b)

This work was done as a part of the “Green cities and settlements” (GREENSETTLE) ENPI CBC project financed by the European Union, the Russian Federation and the Republic of Finland. The project is done in co-operation with Finnish and Russian administrative partners. The goal of this work was to map Finnish experiences and solutions for waste and resource management, and to put forward recommendations for sustainable resource management in project pilot territories. In the theoretical part, a review of best practices in MSW management (MSWM) and producer responsibility system in Finland is introduced. The challenges of sustainable MSWM in sparsely populated Northern areas are also discussed. In addition, case studies of MSWM systems in the North are analyzed. The financial instruments supporting MSWM systems and information about costs of well-functioning MSWM system are also

presented. In the experimental part, the process of strategic MSWM planning is outlined and, finally, waste recovery scenarios are suggested for the city of Kostomuksha.

THEORETICAL PART

2. Waste legislation

2.1 The Waste Framework Directive

Directive 2008/98/EC, the Waste Framework Directive (WFD) presents the basic concepts and definitions related to waste management (e.g. definitions of waste, recycling and recovery). It also defines when the waste is not waste but becomes a secondary raw material (end-of-waste criteria), and what is the difference between waste and by-products. The WFD presents basic waste management principles as it requires that waste need to be managed without endangering human health and harming the environment. EU Member States should follow the waste management hierarchy (figure 1). (European Commission 2012a)



Figure 1. Waste hierarchy. (European Commission 2012a)

Prevention is the first in the priority order, then, in descending order, preparing for the re-use, recycling, other recovery and disposal (table 1). (European Commission 2012a)

Table 1. The stages of the waste hierarchy. (Directive 2008/98/EC)

Stages	Include
Prevention:	Using less material in design and manufacture, keeping products for longer, re-using and using less hazardous materials
Preparing for re-use:	Checking, cleaning, repairing, refurbishing, whole items or spare parts
Recycling:	Turning waste into a new substance or product including composting
Other recovery:	Includes anaerobic digestion, incineration with energy recovery, gasification and pyrolysis which produce energy (fuels, heat and power) and materials from waste; some backfilling
Disposal:	Landfill and incineration without energy recovery

Directive 75/442/EEC on waste has been codified in 2006. Codification means a process of legal texts being revised several times are codified into one new text which then replaces all the previous versions without legal or political. The codified Directive 2006/12/EC was the only legally valid version of the WFD until 2008. In 2005, the Commission proposed revising WFD. This revision updated the waste legislation and merged, streamlined and clarified legislation as well. The revised WFD, Directive 2008/98/EC on waste has been adopted by the Council on 20 December 2008 and it entered into force on 12 December 2008 and the deadline for the transposition of the revised WFD into national legislation of the EU members passed on 12 December 2010. (European Commission 2012b)

Directive 2008/98/EC also enforces the "polluter pays principle" and "extended producer responsibility" (table 2). It also includes recycling and recovery targets to be achieved by 2020 as follows: 50% preparing for re-use and recycling of certain MSW materials and 70% preparing of construction and demolition waste for re-use, recycling and other recovery purposes. The WFD requires that EU Member States have waste management plans and waste prevention programmes. (European Commission 2012a)

Table 2. Relevant articles of WFD (2008/98/EC)

Article 4: Waste hierarchy

- The waste management hierarchy (WMH) is a preference of waste management options
- The currently defined WMH is:
 - Waste prevention
 - Preparing for re-use
 - Recycling
 - Other recovery, e.g. energy recovery
 - Disposal

Article 5: By-products

- A substance or object resulting from a production process, the primary aim of which is not the production of that item

Article 6: End-of-waste status

- Certain specified waste shall cease to be waste when it has undergone a recovery operation and complies with following criteria

Article 8: Extended producer responsibility (EPR)

- An approach where the producers' physical and/or financial responsibility for a product is extended to the post-consumer (waste) stage of a product's life-cycle.

Article 9: Prevention of waste

- By the end of 2011: report on the evolution of waste generation and the scope of waste prevention incl. formulation of eco-designing policy

- By the end of 2014: setting of waste prevention and decoupling objectives for 2020

Article 11: Re-use and recycling

- Support or re-use and repair network
- By 2015, setting up separate collection of waste at least for paper, metal, plastic and glass to promote high quality recycling
- By 2020, 50w% recycling of paper, metal, plastic and glass
- By 2020, 70w% recycling of construction and demolition waste

Article 28: Waste management plans

- Analysis of current situation, measures to be taken to support this Directive

Article 29: Waste prevention programmes

- Either integrated into waste management plans or separate programmes
-

2.2 Finnish waste legislation

The waste policy and legislation in Finland is based on the EU waste hierarchy (Finnish environment institute 2011b). Finnish waste legislation concerns almost all types of waste. Special wastes, e.g. radioactive wastes, are controlled by separate laws. Although the Finnish waste legislation is mainly based on the EU legislation, it may include stricter standards and limits than EU legislation (appendix 1). Moreover, Finland has legislation on some waste related issues that are not included in the EU legislation yet. (Finnish environment institute 2010a) Over 20 decrees have been issued after 1994 after National Waste Act came into effect. Finland has also National Waste Plan which is required by the EU. (Melanen et al. 2002, 2) The general aim of the waste legislation is to support the sustainable development by promoting reasonable use of natural resources and by preventing the harms and dangers for human health and environment caused by wastes. The waste legislation has regulations for the promoting the utilization of wastes, organization of the waste management, preventing of the littering and cleaning of the littered areas. In addition, the legislation includes the regulations for the preventing measures like preventing the formation of waste and the reduction of the amount and harmfulness of waste. The Environmental Protection Act regulates the environmental pollution prevention as well. (HE 199/2010 vp , 6)

The Finnish Waste Act, the Finnish Waste Decree and the Decision 659/1996 of the Council of State cover the transports of wastes within Finland. The professional collection and transportation of waste need to be reported to the National Waste Register kept by the Regional ELY Centers according to the Waste Act. The responsibility of the owner or holder of the waste is to check whether the collector or transporter of the waste has registered his activities with the ELY centre and that the

registration covers the waste transportation as well. Moreover, the owner or holder of the waste need to check that the waste collector or the waste consignee have a valid environmental permit issued by the authority, or else the waste or hazardous waste must not be given to the waste collector or the waste consignee. The validity of the permit can be checked with the regional environmental centre remarked in the permit and the permit needs to be shown on request. (Finnish environment institute 2011e)

Until 1979, there was no actual waste law in Finland. In 1967, the sanitary law stated that the waste may not cause harm to the human health. In 1979, the first waste act was made. The legislation was about the waste management considering administration, enforcement and financing. Moreover, it was set that waste may not cause harm to environment and that the municipalities are obligated to take care of the local waste issues. (Turpeinen 1995, 268-269). The new waste law came into effect in May 2012. The most important change in the new waste law is that the partial producer responsibility for packaging is turning to full producer responsibility (i.e. the producers or importers of packagings need to take care of the collection, transportation and utilization of packaging material produced in the households as well). Definition of waste is more accurate and clear since some of waste materials can be classified as by-products which can be utilized easier than waste. (Elinkeinoelämän keskusliitto 2011)

Some product groups are under the producer responsibility. Extended Producer Responsibility (EPR) for packaging means that the producer has the obligations to the recovery of packaging and it is prescribed by law. Producers are obligated to finance and organize the collection, preprocessing, recycling, utilization and waste management of their products removed from use. They can take care of this obligation themselves or transfer the recovery obligation to the producer organization (appendix 2). (The Environmental Register of Packaging 2011a) Centre for economic development, transport and the environment for Pirkanmaa is the national authority that is responsible for producer registration and other related issues in Finland (except Åland Islands). (Finnish environment institute 2011b) Producers and producer organizations are obliged to submit their details for the national producer data register. (Finnish environment institute 2011c)

The realization of the producer responsibility system has been insufficient in Lapland, especially in case of packaging materials. When there was only partial producer

responsibility for packages in Finland (until May 2012), the collection targets for Finland were fulfilled already in southern part of Finland and therefore there was no need to establish proper collection network for packages in Lapland. The situation is assumed to be changed with the new Waste law. (Lapin ELY 2011, 31)

3. Municipal solid waste management in EU countries

In 2008, 2 626 million tonnes of waste were produced in the 27 EU countries. It is estimated that 89 million tonnes of food was wasted and 17 million tonnes of packaging was disposed in that area. (Europa 2011, 7) The average amount of municipal solid waste (MSW) generated per person in the EU was 513 kg in 2009 (figure 2) and the amount varied from 316 kg in Czech Republic and Poland to 833 kg in Denmark. (Europa 2011)

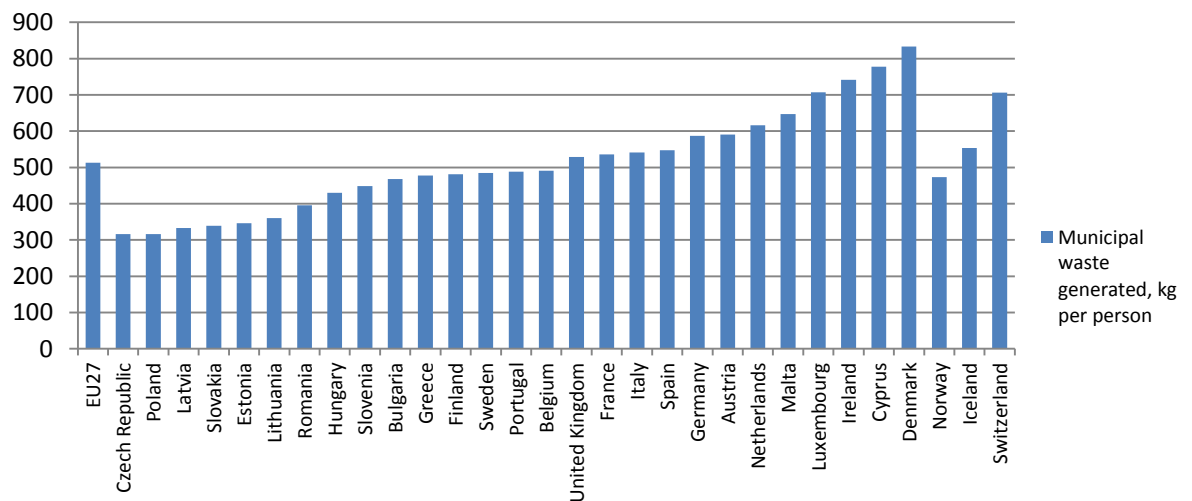

Figure 2. Amounts of produced MSW in EU and other European countries in 2009. (Europa 2011)

The average recycling rate¹ of MSW in EU is about 24% (figure 3). The recycling rates have increased in many EU countries. In Austria, the combined recycling and composting rate is 70% and in Germany 66%. Recycling rate was the highest in Germany (48% of MSW) and Belgium and Sweden (36%) and composting rate were highest in Austria (40%) and Italy (32%). In seven EU countries less than 10% of MSW was recycled or composted. (Europa 2011)

¹ In EU, recycling statistics include all the recovery operations with which waste materials are reprocessed into products, materials or substances for the original or other purposes

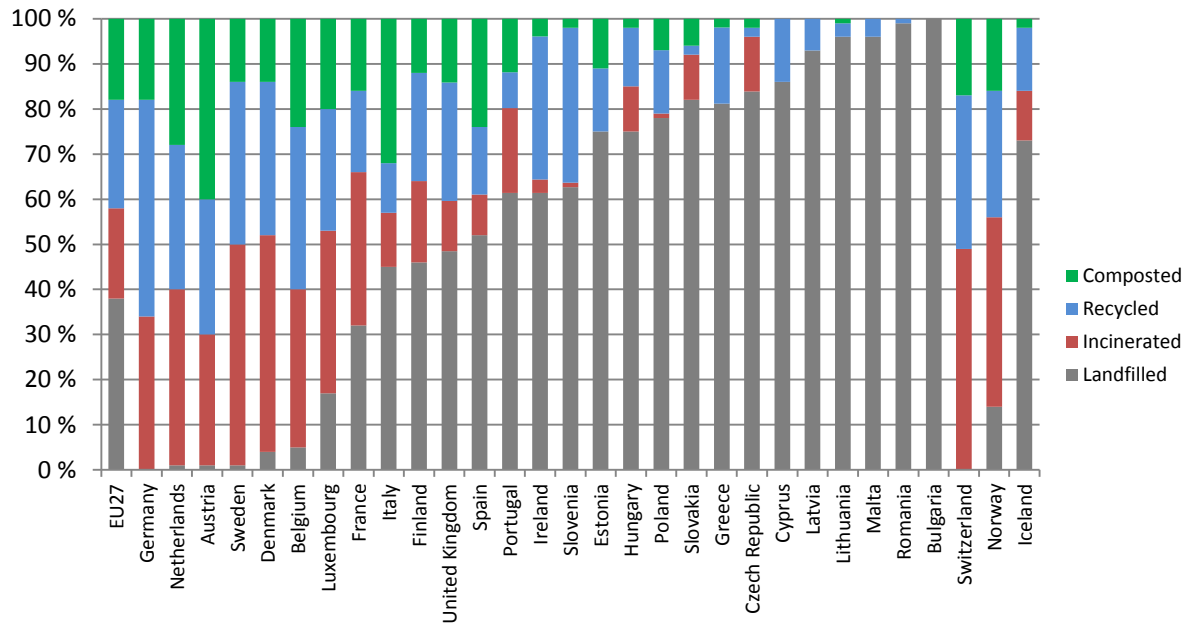

Figure 3. Treating of MSW in EU and other European countries. (Europa 2011)

The amount of landfilled and incinerated waste varies a lot in EU, since in six EU countries less than 5 % of MSW is landfilled but, on the other hand, Bulgaria landfilled all of their MSW and Romania, Malta and Lithuania landfilled 95-99% of MSW produced. In Sweden, 49% of MSW was incinerated and 48% in Denmark, whereas in ten EU countries the share of the incineration is 1% or less. (Europa 2011) If the strategic waste management infrastructures of the countries are in the developmental stage, there may not be high recycling rates and they may miss the incineration plants totally (e.g. Bulgaria, Cyprus, Greece, Malta). It is estimated, that if countries such as Denmark, Finland, Luxembourg, Norway, Austria already have quite high level of energy use of MSW, only a marginal recycling may be inhibited because of the incineration. This may not be environmentally disadvantageous if it prevents the poor-quality recycle from being shipped to the third countries outside of the EU. Moreover, usually the countries with high recycling rates use much waste as energy. (Europa 2011, 33) For example, in Sweden about 35.4 % of the household waste is recycled, 13.8 % goes to biological treatment, 48.4 percent is treated by incineration with energy recovery and only 1,6 % is landfilled (Avfall Sverige 2010, 8).

Usually both the material use and energy use of waste is in high level in several European countries (figure 3). According to the European report (2011, 7), it cannot be said from statistics that energy recovery inhibits material use since there is a weak positive correlation between a high material use of waste and a high energy recovery

rate. Much of the energy use and material use rate issues depend on the waste management history, physical geography and different kind of level of the economic development in each country. Usually EU countries do not need their incineration plants to meet the 60% recovery target.

During the years 1998-2008 the population of 15 EU countries grew 5.4 % but, according to the report of European (2011, 7, 27), the amount of incinerated and landfilled packaging waste decreased strongly (57%) during the same time period (figure 4). The decline is assumed to be due to the increased recycling rate since the consumption of packaging increased during that time. It is noteworthy, that the packaging production and disposal have decoupled from economic growth since growth in GDP was much faster (48%) than the increase of the amount of packaging put on the market (10%). Moreover, ageing of the population and the trend toward smaller households is assumed to lead to the buying of greater number of packaged goods. (European 2011, 7)

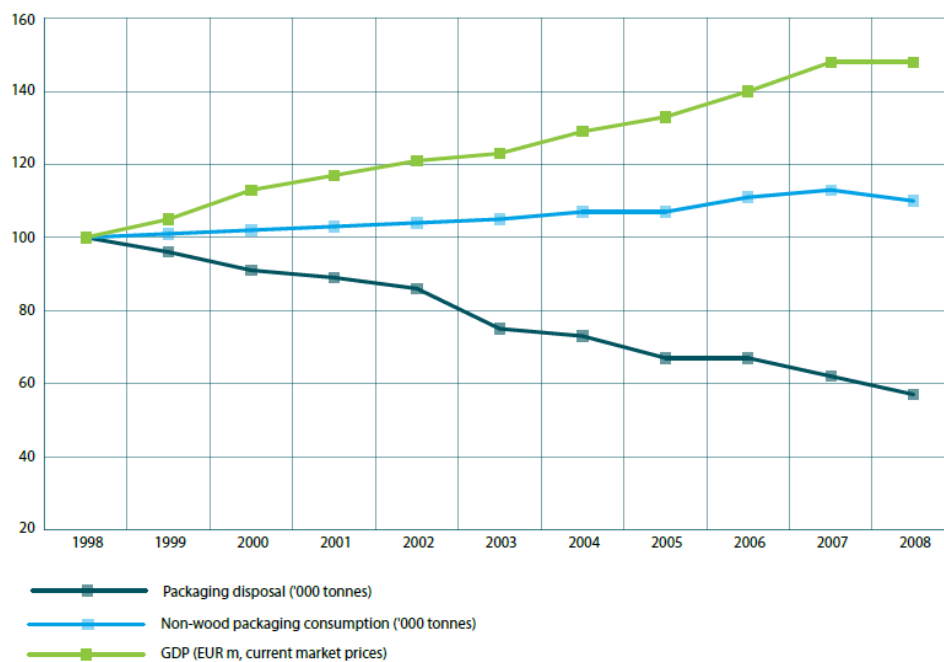

Figure 4. Timeline of GDP, packaging consumption and packaging disposal in some EU countries. (European 2011)

Per capita consumption of packaging grew by 27% and use of paper and board packaging 7% whereas the consumption of glass packaging fell by 7% and demand for metal was quite stable. In some countries the glass bottles have been replaced by non-refillable PET. Also the beverage containers legislation and improved opportunities for

deposit-bearing cans (more outlets and vending machines) may affect the amount of metal packages. In Germany, the waste management of household packaging was opened to the competition in 1998 and the mandatory deposits were introduced in 2003. (Europen 2011, 7, 29, 36)

Lichtenstein recycled 85% and Belgium 79% of their packaging waste whereas Cyprus and Romania recycled only 34%. It seems that if the recycling rates of the packagings have been high for many years, they may stay stable. For example, in Germany, Sweden, Austria, Belgium and the Netherlands the average recycling rate was 69% already in 1998 and 70% in 2008. On the other hand, the change can be fast: in Ireland, the UK, Italy, Spain, Greece and Portugal the average recycling rate rose from 30% to 58% during the same ten years of time period. The most convincing examples are Ireland (recycling rate rose from 15% to 62%) and UK (from 28% to 62%). It is obvious, that the new EU members can learn from the experiences in Western Europe and achieve strong results in recycling of packaging materials. (Europen 2011, 28)

In countries where the level of the material recovery is high, it seems that the ban on the landfilling of organic waste has been effectively decreasing the amount of landfilled MSW. The reduction in the amounts of landfilled wastes was seen already during the first year after the ban was set in Germany, Sweden and Australia, and bit later in Denmark. In these countries, there are also other measures in use to decrease the amount of landfilled MSW, for example separate collection systems for packaging materials and landfill taxes. In Hungary the combination of landfill ban and separate collection systems has been effective, whereas the combination of landfill bans, landfill taxes and separate collection systems has diverting waste in the Netherlands and Slovenia. (EEA 2007, 18)

In countries that have no sophisticated material recovery and incineration systems, the establishment of separate collection systems for packaging waste has been successful in reducing the amount of landfilled waste already during the first year in Czech Republic, Poland and Latvia. England has requirements to collect at least two types of recyclables from households. It seems that landfill taxes may lower the amount of landfilled waste and increase the recovery rate of heavier waste streams but that they are not very effective in waste reduction. (EEA 2007, 18)

According to the report of European Commission (2012c), 18 EU Member States currently have landfill taxes for the disposal of MSW sent to legal landfills. It seems that countries with high total charges for landfill have low levels of MSW landfilled (figure 5). Usually the countries with total charges of over 100 euros are landfilling 5 % or less of MSW and countries with total charges of less than 40 euros are landfilling more than 60 % of the MSW. In addition to the taxes and total charges, countries with low levels of landfilling have also restrictions on landfilling. (European Commission 2012c, 3-4)

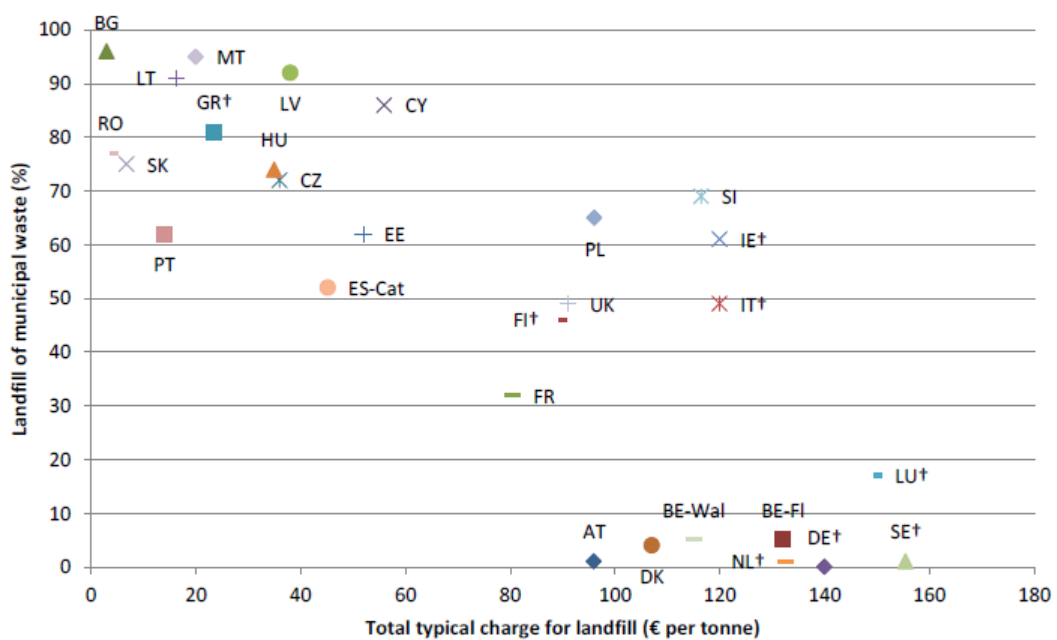

Figure 5. Total landfill charge and percentage of landfilled MSW in 2009 (European Commission 2012c)

There may be correlation between the total landfill charge and recycling and composting; the higher the landfill charge is the higher percentage of MSW is recycled and composted. It is noteworthy that, although other policies (e.g. to promote recycling, to encourage prevention, extended producer responsibility) also influence recycling and composting rates, the higher landfill charges helps the use of waste for recycling and composting instead of landfilling, and therefore move waste treatment up the waste hierarchy. The effect of bans seems to be the reduction of the landfilling of MSW and the increase in the amount of MSW incinerated or sent to mechanical biological treatment. (European Commission 2012c, 54- 55)

Six EU countries have incineration taxes for the disposal of municipal waste. There is a trend that higher incineration charges are usually associated with higher recycling and composting rate which may indicate that higher incineration charges may assist recovering. The landfill tax is always higher than the incineration tax. 17 EU countries have pay-as-you-throw (PAYT) systems for MSW. Producer fee schemes for packaging are in use in 24 EU countries. No conclusive patterns were observed between the producer fee schemes and the packaging recovery/recycling performance in the EU countries. (European Commission 2012c, 5-6, 9)

In some new Member States, the implementation of the EU waste laws, changes in data reporting and the definition of municipal waste may have decreased the amount of MSW. It seems that the waste treatment is moving from landfilling to energy recovery, as a result of the implementation of policies and perhaps economic instruments. In the six EU countries with high recycling rates and very low landfill rates strong combinations of economic instruments and often restrictions/bans on landfilling of MSW is in use. In Germany in particular are implemented very successful economic instruments (e.g landfill bans, PAYT and producer responsibility schemes). (European Commission 2012c, 25)

4. Municipal solid waste management in Finland

4.1 Wastes generated in Finland

According to the statistics, it seems that the amount of waste in Finland is increasing. In 2004, the amount of waste was about 66 million tonnes (excluding the manure used in agriculture and logging waste left in the forest), in 2007, about 74 million tonnes (Suomen ympäristökeskus 2012), in 2008, about 80 million tonnes (HE 199/2010, p 17) and, in 2009, almost 85 million tonnes (Suomen virallinen tilasto 2011a). Most of the waste is produced in the construction, mining and quarrying sector (figure 6). The majority of the construction waste is mineral waste whereas the mining and quarrying sector generates mostly waste stone, ore dressing sand and excess soil. (Finnish environment institute 2011a)

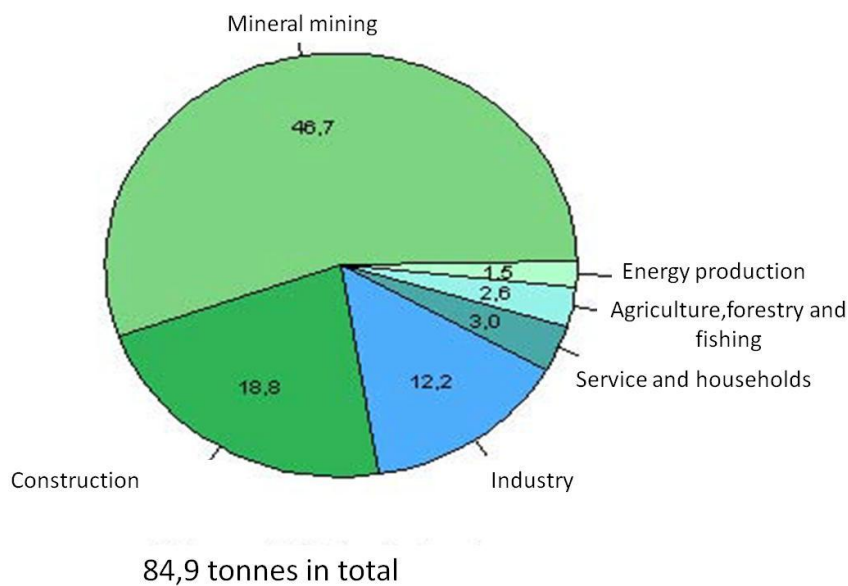

Fig. 6. Amount of wastes by sectors in 2009 (million tonnes). (Suomen virallinen tilasto 2011c) The sector Service and households includes the scrap vehicles and sewage sludge of municipalities in addition to the municipal wastes.

Amount of MSW seemed to be rising quite steadily for many decades till the year 2008 (figure 7). In 2009 about 2,56 million tonnes of MSW were collected (Suomen virallinen tilasto 2010a) which was 7,4 % less than in 2008 (Suomen virallinen tilasto 2011c). Altogether 1,13 million tonnes municipal waste were landfilled in 2009, which was 16 % less than in previous year (Suomen virallinen tilasto 2010a). Altogether 478 kg of municipal waste per year per inhabitant was produced in 2009 in Finland (Suomen

virallinen tilasto 2010b) and, in 2010, the amount of municipal waste produced and landfilled has still slightly decreased (figure 7) so that the amount of municipal waste per inhabitant was then 470 kg (Suomen virallinen tilasto 2011d). About half of MSW was foodstuff, wastepaper and cardboard. (Suomen virallinen tilasto 2010b) and about 80 % is biodegradable material (HE 199/2010 vp , 18).

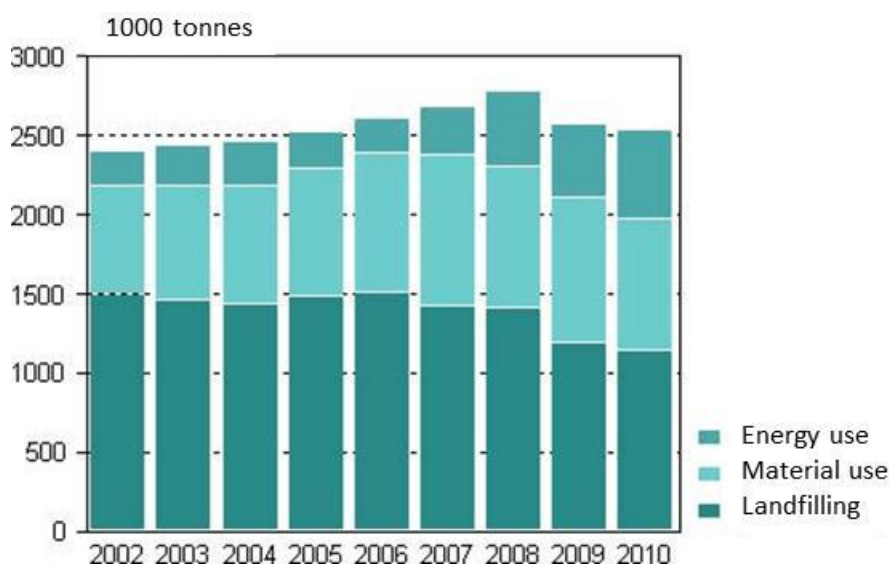

Figure 7. Amount of municipal solid waste according to their treatment in 2002-2010. (Suomen virallinen tilasto 2011d)

About 60 % of MSW is generated by households and the rest is produced in the service sector (Finnish environment institute 2010a). In addition, the share of households and public sector is estimated to be that 86 % is from households and 14 % is from public services (table 3, Ympäristöministeriö 2010a, 18).

Table 3. Estimates of MSW amounts produced in households, public services and private services (Kaplas 2009 in Ympäristöministeriö 2010a)

Waste sector	Households and public services (tonnes/a)	Private services (tonnes/a)
Mixed waste	1 199 000	376 000
Paper and cardboard	258 000	132 000
Bio-waste	156 000	121 000
Waste wood	3 000	29 000
Plastic	24 000	25 000
Others and unclassified	215 000	59 000
Total	1 854 000	742 000
All in total	2 596 000	

4.2 Waste management services in Finland

Waste management in Finland is a basic service affecting the health and environment of the citizens and it is part of the infrastructure of the municipalities. Waste management consists of collection, transportation and treatment systems organized by municipalities, companies and organizations with producer responsibility (figure 8). Municipals are obligated to organize municipal solid waste management (MSWM). (Jätelaitosyhdistys 2011b) The municipality may organize MSWM by itself, or together with other municipalities. Regional joint-stock and federation of municipalities waste stations have been founded and they can work effectively and have resources for development work according to tightened environmental demands. There are currently 40 regional waste management firms providing services to 350 municipalities and 4,8 million people in Finland. (Finnish environment institute 2011d) Collecting, transporting, handling and utilization services organized by waste companies are countrywide. Municipal waste companies are cooperating with industry and producer organizations. Waste stations may use competitive bidding and buy main part of their services from private companies according to the public procurement method. (Jätelaitosyhdistys 2011b)

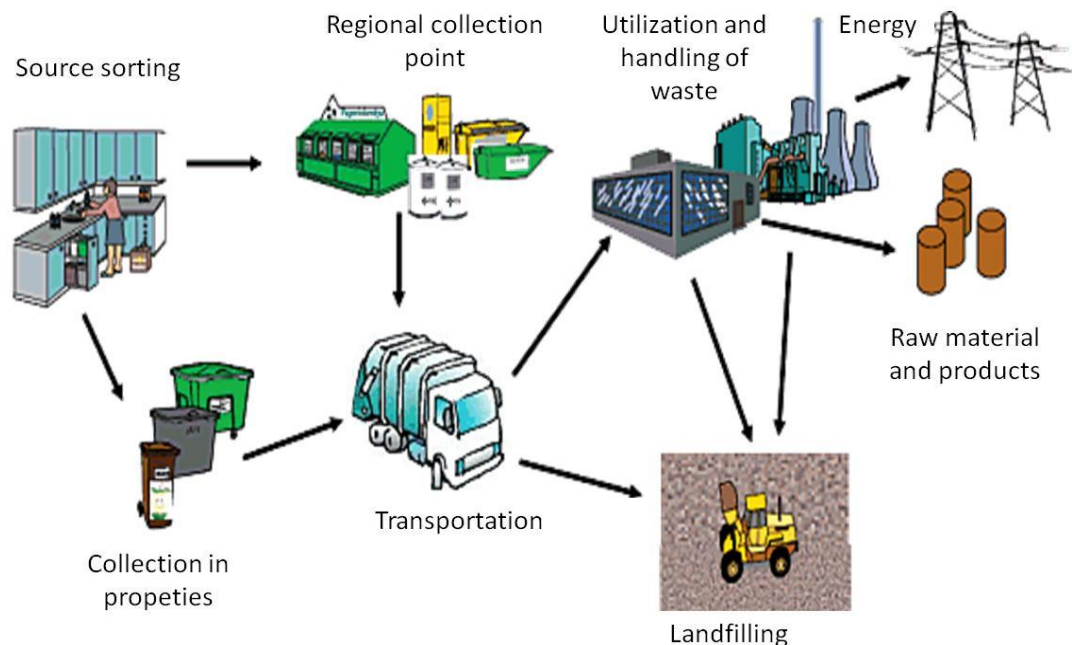

Figure 8. Diagram of municipal solid waste management system in Finland (Kuntaliitto 2006).

4.2.1 Sorting

Efficient sorting of waste in households and companies helps to collect the usable materials for example to composting or for recycling. It is possible to improve the recovery of MSW by developing sorting and considering the recycling of packaging waste already at the planning phase. Energy recovery is seen as a complementing part of material recovery in many European countries, as in those countries both material and energy recovery is on a high level. (Jätelaitosyhdistys 2012a)

4.2.2 Collection

Property-owners and housing companies are obliged to organize waste collection points and containers for household waste and the producers of waste should take their waste to these collection points (Finnish environment institute 2011d). Different types of wastes are separately collected to make handling and utilization easier. In addition, it is reasonable to collect waste which still has market value, e.g. metal and paper. Municipal waste companies have organized collection points for the collection of recoverable waste countrywide. In addition, recoverable materials are collected from properties (if collectable materials are produced enough when considering economic and environmental reasons) and by organizing collection events. Collection of hazardous waste is comprehensive in Finland as well. (Jätelaitosyhdistys 2011c) Most commonly, paper, glass, organic wastes, hazardous wastes and cardboard are separated but energy waste for incineration and metallic wastes are also collected separately in some localities. (Finnish environment institute 2011d) Almost all citizens are able to use the separate collection of paper, glass and hazardous waste. There is separate collection for metal in ca. 96% for cardboard in ca. 97%, and for bio-waste in 68% of Finnish municipalities (Hänninen 2009, 40).

Collection containers can be surface collection containers or deep collection containers. The more traditional way to collect the waste is to use the surface collection containers (figure 20, appendix 3). Usually the size of bio-waste container is 140 liters or 240 liters and for other types of wastes 240 liters or 600 liters. Different colors in containers are used for different types of wastes. Usually town houses and apartment houses have their own containers for paper, card board, metal and glass, but carton liquid packagings, batteries and hazardous wastes are collected to regional collection points. Single family houses usually have containers only for bio-waste and dry waste. Usually containers are emptied once a week (depending on the waste fraction and waste regulations) by using

garbage trucks. Problems with surface containers are that they are quite small but they still need relatively large space (Hänninen 2009, 41-42).

Deep collection containers, like Molok and Uppo, are partially below the ground with the lifting bag made of a strong textile material inside the container (figure 21, appendix 3). Deep collection containers are much larger than surface collection containers and they only need to be emptied every other week (or every 1-6 weeks) depending on the waste type and waste regulations. The size of the container for bio-waste, glass and metal is 1300 liters, for paper and card board 3000 liters and for dry waste 5000 liters. Bags inside the containers are emptied by the truck by lifting the bag out of the container and then releasing the mechanism at the bottom of the bag. Usually the costs of the using of deep collection containers are lower since they don't need to be emptied so often. Moreover, they don't need so much space aboveground. (Hänninen 2009, 42-43, Molok ltd 2009)

Usually, properties of households are using waste containers of 240 (single family houses, small terraced houses) and 600 liters (large properties), whereas properties of public sector and regional collecting points have containers of 600 liters or even large-scale containers. The amount of mixed waste produced in households and in public sector is estimated to be 1,2 million tonnes yearly. In total, 95 % of mixed wastes is collected by using manually moveable containers and only 5 % is collected by using large-scale containers (e.g. deep collection containers). (Ympäristöministeriö 2010a, 27)

4.2.3 Transportation

Local authorities usually organize waste transportation through agreements with private waste companies, since most municipalities do not have waste collection vehicles of their own. (Finnish environment institute 2011d) Municipal solid waste management requires effectively organized logistics i.e. from collection and transportation to handling and utilization. Most of the waste transportation companies are selected by using of competitive bidding but some of the properties use contractual waste transportation by making the contract with the transportation company directly. The using of competitive bidding may lower the cost on transportation, since the municipalities can buy transportation services in bulk and, as major customers, they have advantage over other competitors. (Jätelaitosyhdistys 2011d)

If the municipality is organizing the waste transportation, it can set the price of the transportation for the owner of properties. This system was in use in 33% of municipalities and it covered 50 % of the citizens in 2006. The owner of property may use competitive bidding and select the contractual transportation with the waste company directly (in about 47 % of municipalities and 40 % of the citizens). The rest of the municipalities are using both systems. (Ramboll 2008, 5)

4.2.4 Waste treatment

Municipalities are obligated to organize the utilization and treatment of the waste that they are responsible for. All the waste that municipalities are responsible for, including the wastes from contractual waste transportations, needs to be transported to the adequate place organized by municipalities for their utilization and treatment. (HE 199/2010 vp, 20). Waste treatment means recovery or disposal operations, including preparation prior to recovery or disposal. In essence, it involves converting the waste material to more harmless or more useful form, considering future utilization. Waste can be treated by biological, mechanical and thermal processes. In Finland, waste treatment is centralized in large regional treatment centers where the treatment can be done effectively and economically. All the centers have processes for different waste types and disposal places for the wastes that are not recoverable. (Jätelaitosyhdistys 2011e)

In biological treatment, the bio-waste is decomposed by using composting or anaerobic digestion to more harmless and safer form and that can be used in soil improvement. Biogas produced in anaerobic digestion consist mainly of methane which can be used as a source of energy. Biological treatment is used for municipal bio-waste and sewage sludge. For large amounts of bio-waste there are treatment facilities where the bio-waste can be treated in closed reactors. (Jätelaitosyhdistys 2011e)

4.2.5 Landfilling

Mechanical pre-treatment, e.g. crushing and screening is often used when there is a need to separate or reshape different fractions of waste before utilization. The method is used for the processing of MSW to recovered fuel (REF). (Jätelaitosyhdistys 2011e) Waste fractions that cannot be utilized are transported to landfills for final disposal. As the degradation of biodegradable wastes generates greenhouse gases, the landfilling of bio-waste will be banned in future and only inorganic wastes such as ashes from energy production can be placed in landfill. (Jätelaitosyhdistys 2011e) The number of landfills

has been declining strongly during the past years because of the strict requirements for the base structure of landfills (table 4, HE 199/2010 vp)

Table 4. Number of landfills in Finland in 2009 (HE 199/2010 vp , 21-22)

Landfills in Finland in 2009	
Landfill for soil	167
Landfill for hazardous waste	27
Landfill for permanent waste	37
Landfill for regular waste (inc. municipal waste)	137
Other landfills	29
Total	397

4.3 Recovery rates of wastes in Finland

Waste recovery rates vary depending on the waste sector. In 2009, the mineral and wooden wastes and metal scrap formed the largest group of the total amount of wastes in tonnes recovered as material. The majority of the mineral wastes are landfilled and wooden wastes are mainly used as energy. Almost all metal scrap and glass are recycled. (Finnish environment institute 2011a) In 2004-2007, most of the wastes were landfilled but the portion of landfilled waste has decreased during 2004-2007 from 63,2 % to 59,5 %. The share of wastes used as a material did not change notably during the same time period (about 28.4 %) but the portion of wastes used as energy increased from 8,2 % to 12 %. (Suomen ympäristökeskus 2012).

In 2009, about 54 % of municipal waste was recovered as material or as energy (figure 7) (Suomen virallinen tilasto 2010b). This amount is extremely high since the recovering rate is usually about 40 per cent of the total amount of generated wastes in Finland. (Finnish environment institute 2011a). The recovering rate of municipal waste has increased because of improved sorting and separate collection. (Finnish environment institute 2010a) The amount of waste usually increases as the standard of living of inhabitants becomes higher (European Commission 2011). In 2009, consumption expenditure of households decreased 1,8 % and net sales of the service sector decreased 7,5 % in Finland (Suomen virallinen tilasto 2010b) which may partially explain the decreased amount of waste.

In 2010, the recovery rate of waste as material or as energy was even higher, 55 % (table 5), but it is noticeable that it was not due to improved recycling since the amount

of material use decreased strongly and the energy use of waste increased. The energy use of waste material is now 22 % of the municipal waste produced yearly and it has increased 2,3 fold in four years. The amount of collected waste paper and cardboard decreased significantly (ca. 20%) in 2010, whereas the amount of waste electronic and electrical appliances (WEEE) waste has increased steadily to be now five-fold compared to the beginning of the last decade. (Suomen virallinen tilasto 2011d)

Table 5. MSW in 2010 in Finland (tonnes) (Suomen virallinen tilasto 2011d).

	Amount of waste		Material use	Treatment	
	Tonnes	Percentage		Energy use	Landfilling
Mixed waste total	1 519 020	60.3 %	42 889	373 436	1 102 695
Separately collected of which	1 000 984	39.7 %	779 263	183 695	38 026
Paper and cardboard	342 579	13.6 %	311 355	30 692	532
Bio-waste	300 443	11.9 %	294 975	220	5 248
Glass	76 703	3.0 %	75 684	4	1 015
Metal	14 465	0.6 %	14 152	42	271
Wood	23 662	0.9 %	5 563	16 866	1 233
Plastic	13 227	0.5 %	11 969	1 258	0
WEEE	50 832	2.0 %	45 187	1 386	4 259
Other	179 073	7.1 %	20 378	133 227	25 468
Total	2 520 004	100 %	822 152	557 131	1 140 721

The most recovered waste materials are paper and cardboard, bio-waste, glass and metal. (Jätelaitosyhdistys 2011f). In 2008, about 6 % of municipal solid waste was composted and about 2 % was anaerobically digested for biogas production. (HE 199/2010 vp , 22)

A key objective of municipal solid waste management is to reduce the amount of landfilled organic waste. One instrument to achieve this energy use of MSW (figure 9). For waste incineration, different kinds of combustion techniques can be used. For sorted municipal waste fixed bed combustion is used, whereas dual combustion (e.g. fluidized bed combustion, gasification) is suitable for clean and homogenous packing and wooden waste from trade and industry. The waste incineration directive (nro 4) requires efficient purifications and controlling for the emissions. (Jätelaitosyhdistys 2012a)

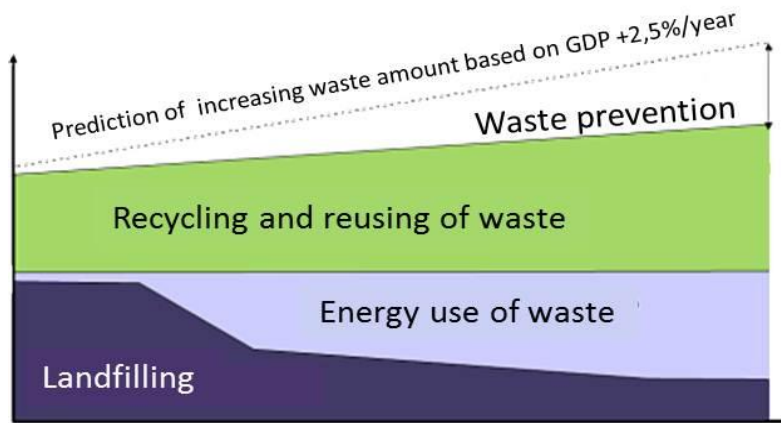

Figure 9. The waste for the energy use is taken from the landfilled waste segment Jätelaitosyhdistys (2012a)

In 2009, about 300 000 tonnes of mainly municipal waste was burned in waste incineration plants in Finland. The amount of dual fuel for conventional power plants has been 100 000-200 000 tonnes (5-7 % of municipal solid waste) per year depending on the market situation. Dual fuel is usually made from separately collected combustible waste fractions. (HE 199/2010 vp, 22) Waste incineration plants in Finland are located in Turku, Riihimäki and Kotka. In addition, some amount of waste of good quality is burned in conventional power plants as a dual fuel. According to the current plans, there will be enough capacity for waste incineration in Finland in 2015 since the capacity of plants that are in operation, under construction or consideration will be 1,14 million tonnes of waste altogether (figure 10). About 70-80% of capacity is reserved for municipal waste and the rest of the capacity is for energy use of wastes from industry. According to the present strategies, one third of municipal waste is to be used as energy. (Jätelaitosyhdistys 2012a)

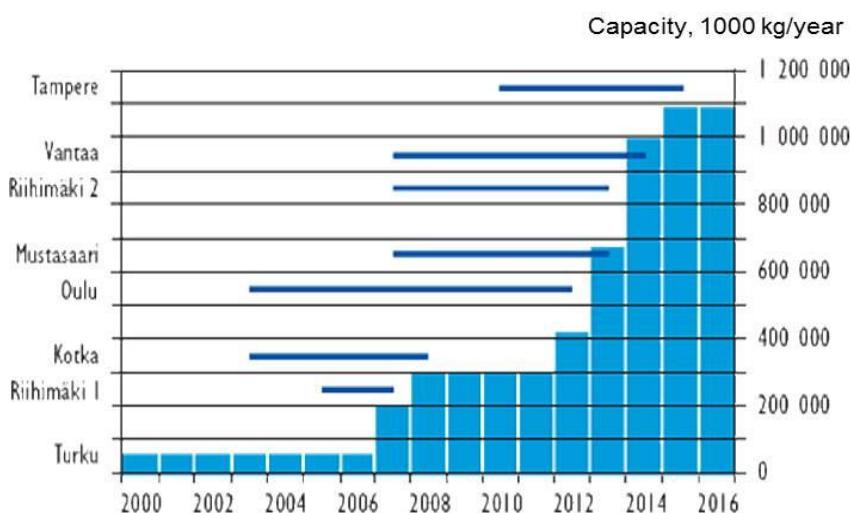

Figure 10. Waste incineration plants that are in operation, under construction or consideration and the increase of waste incineration capacity. (Jätelaitosyhdistys 2012a)

There are much more restrictions in material use of waste material than in energy use. The basic requirement for the establishment of the recycling systems is the existence of a recipient facility that can utilize the recovered waste. In addition, there needs to be demand for the product made from waste. The recovered waste material is always competing with virgin raw material and is considered as substitutive material for them. The waste fraction must be suitable for the production process of the product so that the production will preferably not be more expensive than when using virgin products. Ideally, the same process should be able to utilize virgin raw material if there is insufficient amount of waste material available. (Myllymaa et al. 2008a, 17)

Sometimes the location of the producers of the waste and users of the waste material are not situated near each other. The transportation distances add to the costs of waste recovery. In some cases the costs of the waste recycling are so high that they outweigh the costs of the avoided material and energy expenditures. (Myllymaa et al. 2008a, 52)

In case of waste derived fuel, called recovered fuel (REF), the average price for REF is estimated to be 0 euro/tonne. The price for REF made from waste wood is positive, whereas the producer of the REF from mixed combustible packaging waste needs to pay for the incineration. Therefore, the estimated selling price of the REF fuels is negligible (Ympäristöministeriö 2010b).

4.4 Economic instruments of MSWM in Finland

The purpose of economic instruments is to create incentives for people to change their behavior to cause less environmental pressure e.g. finding ways of preventing waste production or selecting less damaging waste management options. Common economic incentives are fees for collection and treatment of waste and taxes, charges and fees like taxes on landfill and packaging. (European commission 2003, 44)

It is estimated that the overall costs of waste management as a turnover of companies in waste sector in Finland were about 1750 million euros and the number of personnel 4300 in 2007. These figures don't include management of sludge and contaminated soil. The net costs of waste management to the waste producer are 1148 million euros annually (figure does not include the cost of producer responsibility system) (table 6). While the amount of MSW of total waste amounts is about three percent but the cost of

municipal solid waste management (MSWM) attributes to 36 percent of total waste management costs. (Ympäristöministeriö 2010a)

Table 6. Summary of net costs of the waste management in different waste sectors (including waste taxes, VAT 0%) (Ympäristöministeriö 2010a)

Waste producer	Waste amount (million tonnes/year)	Costs (million euros/year)	Average costs (euros/tonne)
Households and public services*	2	414	205
Trade and other private services	1	65	109
Housebuilding and earthwork	23	440	19
Extractive activities	22	60	3
Industrial activities	18	92	5
Energy management	2	24	15
Water supply services	1	40	40
Agricultural industry	2	13	6
Total	71	1 148	

*Without composting in properties

The costs of MSWM have increased due to the investment in landfills, waste incineration plants and other treatment facilities. The recycling of waste material causes costs as well since the waste material need to be preprocessed for the production and usually the waste material is not very valuable. Incomes of waste management consist of reception fees of waste and selling of the material and energy. The world market price of raw materials has fluctuated strongly during the past years and this has affected the waste sector as well. There has been a demand for some waste material as the raw material prices have increased and the investments in the Far East have increased. On the other hand, the prices of the recovered materials have dropped because of the economic depression and need decreased due to reduction of new investments. Therefore, both the demand and supply and the price of waste material have fluctuated strongly. (HE 199/2010 vp, 22)

4.4.1 Waste taxes and charges

Further to the Waste Tax Act (1126/2010), tax is levied on all waste deposited at landfill if its utilization is technically feasible and environmentally justifiable and, if by imposing the tax, waste can be made more commercially exploitable. The aim of waste taxes is to improve waste recovery and to decrease the quantity of landfilled waste. Waste taxes are for wastes that are brought to public landfill sites. If wastes are suitably

treated e.g. through composting or incineration, there is no need to pay waste taxes. The owner of the landfill pays the waste taxes. The producer of the waste covers the costs by paying the fees when delivering wastes. Waste taxation has helped to reduce the quantity of wastes of construction, commercial and industrial activities, but they are less effective in limiting the amounts of household waste. From the beginning of 2011, the waste tax is 40 euro/ tonne of waste sent to a landfill and from 2013 50 euro/tonne. The Finnish Customs authority is liable for the collecting and controlling the waste taxes. (Finnish environment institute 2011f)

Drinks packaging taxes are paid on packages for alcoholic beverages, soft drinks, bottled water and certain other drinks packages. The aims of these taxes are to increase packaging re-use, lower the quantities of landfilled drinks packages, and to reduce littering. The tax is currently 0.51 euro/liter for non-returnable packages. As a result, since in 2006 the amount of returnable drinks packages in Finland is 98% for refillable packages and 88% for recyclable packages . There is special legislation on the taxation of the manufacture of certain types of drinks packaging (1037/2004), as well as statutes in the Waste Act and a related decree on collection systems for returnable drinks packages (180/2005) in Finland considering the returnable deposit system. (Finnish environment institute 2011f)

Municipal waste charges are collected for the establishment, maintenance, decommissioning and purification of waste treatment facilities and for the transportation of wastes. The aims of the waste charges are to reduce the quantity and risks of the waste generated and to improve waste recovery. Waste holders pay waste charges and the rates are set by municipalities. The charges include transportation and waste treatment fees and many times they are lower for the sorted wastes and for wastes that can be recovered in comparison with mixed wastes. In 2007, the average fee was 102 euro/tonne of municipal waste and 68 euro/tonne for bio-waste. (Finnish environment institute 2011f) According to the Finnish Solid Waste Association (Jätelaitosyhdistys 2012b) the handling price for the mixed waste in 2010 was ca. 98 euro/tonne (VAT 0%) which includes waste taxes of 30 euro/tonne. The handling price of wastes is independent of the transportation system.

4.4.2 Costs of MSWM in households and public services

In the report of the Ministry of Environment (Ympäristöministeriö 2010a, 25) the economic impact of waste management was estimated based on statistics and surveys. The collection of MSW is organized either by using property specific or regional waste collection.

Property specific waste collection

Municipals collect the waste in different ways: as separate section, as mixed waste, or by a “two bags system” (bio-waste in black bag and energy waste in white bag) (table 7). Bio-waste is usually collected by using 240 l containers (95 % of bio-waste) or much larger containers (volume of 3 m³). Paperboard and cardboard is collected only from the largest properties. As paper waste falls under Extended Producer Responsibility systems, properties need to pay only for the purchase and maintenance of bins. (Ympäristöministeriö 2010a, 26-27)

Table 7. Estimate of annual waste amounts collected from properties (produced in households and public services). (Ympäristöministeriö 2010a, 26)

Waste section	Households and public services (tonnes/a)
Mixed waste	1 185 000
Energy waste	40 000
Bio-waste	156 000
Paper	210 000
Paperboard and cardboard	20 000
Total	1 611 000

The costs of maintaining the waste containers consist of the purchasing, wearing, washing and fixing of the containers. Usually properties purchase containers that are large enough to be emptied only once a week. In single-family houses containers can be emptied every fourth week. Smaller containers are emptied every second week whereas large containers are emptied every 1,5 weeks. The rental price of the 240 liter container is 10-50 euros and of the 600 liter container 14-50 euros. It is estimated that there will be 48 emptying times per every tonnes of mixed waste annually. The cost of the emptying of the waste container consists of the costs of transportation and treating of the waste, and VAT. In addition, there is a waste tax for the waste that is landfilled. If there is no possibility to weigh the amount of the waste, the cost is based on the estimate. Usually the households pay according to the number of emptying of the waste

container. The weight of the waste is possible for example the waste is collected to the interchangeable container. (Ympäristöministeriö 2010a, 30-32)

The collection price of the specific waste sector does not need to be the same that the managing the waste section itself since the idea of the waste law is to direct the waste production according to the waste hierarchy. The handling of the bio-waste and energy waste is subsidized by collection fee from mixed waste. The costs of waste management organized by municipalities are collected fully from the producers of the waste and possible profits are used for the developing the existing system. The profits collected from the sales of the recoverables and excess energy are taken into the account when deciding on waste fees. The emptying fees vary a lot depending on the transportation system, competitive bidding and since they may include different kinds of services (washing of the container, rent). In addition, treatment fee may include costs of organizing the treatment of hazardous waste and recoverables and consultation. (Ympäristöministeriö 2010a, 31-33)

According to the studies of Consumer Agency (Kuluttajavirasto 2010), the emptying of mixed waste container of single-family house costs from 3,78 euros to 11,95 euros average being 6,45 euros. Especially high price spread was in price of emptying of bio-waste containers. Only half of the municipalities have organized the bio-waste collection. The price for the emptying of bio-waste container of single family house costs 7,10 euros in average (varying from 3,17 to 16,71 euros) and in some companies the bio-waste bag is included in price but not always. Only one fifth of municipalities have organized the collection of energy waste from single-family houses. The emptying price was 5,53 euros varying from 3,5 euros to 8,54 euros. (Kuluttajavirasto 2010)

The Association of Environmental Enterprises (YYL 2010) claims that there are no significant differences between contractual and competitive bids in waste transportation in the prices of emptying of waste containers. The price of emptying in contractual waste transportation was 6,11 euros and in competitive bid waste transportation organized by municipalities it was 6,67 euros. (YYL 2010). According to Finnish Solid Waste Association the price for emptying of the mixed waste container is always lower when the transportation is organized by municipalities using competitive bidding compared to contractual waste transportations Association of Environmental Enterprises (2009) has therefore studied the total annual cost of waste management services in

single family houses. The average price of waste management for 377 single family houses was 177,46 euros in contractual waste transportation system and 170,58 euros (inc. VAT) in when the transportation was organized by municipalities using competitive bidding (352 houses). Association of Environmental Enterprises (2009) claims that the differences in prices are caused by the higher waste treatment fee for contractual waste transportation system. In addition it is said that the contractual waste transportation system is more flexible when households want for example extra emptying of waste containers. (YYL 2010)

The total amount of the emptying fees of mixed waste from households and public sector are about 280 million euros in Finland annually (table 8). The total cost of mixed waste management of households and public sector is about 340 million euros annually. (Ympäristöministeriö 2010a)

Table 8. The costs of mixed waste management (Ympäristöministeriö 2010a)

Cost factor	Cost (euros/year)
Transportation	146 131 000
Treating	136 326 000
Maintaining the containers	56 435 000
Total	338 892 000

Regional collection

Regional collection is organized for waste fractions that are not produced in large enough amounts in properties or are not suitable for normal waste transportation. In some municipalities also the mixed waste may be collected to the regional collection points if the area is sparsely populated. Properties use common waste bin which is sustained and emptied by municipalities. Properties pay regional collection fee for this service. (Ympäristöministeriö 2010a, 25)

The costs of MSWM of wastes from households and public services to service providers are estimated to be 211 million euros/year (41 euros per inhabitant/year). Total costs of the waste management of household and public service waste is about 414 million euros yearly (table 9). (Ympäristöministeriö 2010a, 40-41)

Table 9. Summary of the costs of the waste management of the waste from households and public sector in Finland (incl.waste tax, VAT 0%). (Ympäristöministeriö 2010a, 41)

Cost factor	Transportation and handling (euro/year)	Collection containers	Total (euro/year)
Mixed waste	282 457 000	56 435 000	338 892 000
Ekofee	15 876 000		15 876 000
Energy waste	16 013 000	3 032 000	19 045 000
Separately collected bio-waste	23 804 000	3 140 000	26 944 000
Waste paperboard	8 867 000	960 000	9 827 000
Waste paper	0	1 590 000	1 590 000
Sludge from septic tank and cesspit	2 190 000	0	2 190 000
Total	349 207 000	65 157 000	414 364 000

In conclusion, the average cost of waste management per tonne of waste is about 205 euros if cost of containers is included. The costs without containers are 173 euros per tonne. The cost of waste management of solid waste is about 57 euros per inhabitant (excluding the costs of containers) and 67 euros with containers. (Ympäristöministeriö 2010a, 41)

4.4.3 Costs of producer responsibility systems

The aim of producer responsibility is to encourage manufacturers and importers to think through the whole life cycle of their products and it promotes environmentally favorable product planning, waste prevention, the separate collection and recovery of useful wastes, waste re-use and recycling and the incorporation of environmental costs into product prices. In producer responsibility the producer means the manufacturers and importers of the products or, in the case of packaging, packagers and the importers of packaged products (see also appendix 2). It bounds producers to organize the re-use, recovery or suitable treatment or disposal of their products and the wastes related to them, and to cover the costs resulting from those activities. Producer responsibility covers waste electronic and electrical appliances (WEEE); batteries and accumulators; tires from motor vehicles, other vehicles and equipments; cars, vans and comparable vehicles; newspapers, magazines, copy paper, and other comparable paper products and packaging. (Finnish environment institute 2011c) The costs of producer responsibility systems are covered with utilization fees that are collected from the producers (table 10). The utilization fees for packaging materials is 0,4 - 35 euros depending on the material. (Suomen Kuitukierrätys Oy 2012)

Table 10. Utilization fees for packaging (Suomen kuitukierrätys Oy 2012)

Material	euro/tonnes + VAT
Corrugated board	3,5
Industrial covers and sacks	18,0
Cores	18,0
Cardboard packages and paper covers	25,5
Liquid cardboard packages	35,0
Plastic packages	21,0
Plastic packages as a part of recyclable bottle system	-
Aluminum packages	24,0
Sheet tin packages	24,0
Steel packages	5,0
Metal cans with reward	-
Glass bottles with reward	-
Wooden packages	0,4
Others	-

Several organizations are collecting WEEE in Finland (table 27, appendix 4). It is estimated that the management of WEEE cost about 14 million euros annually. Presently, producers are collecting only about half of all the WEEE, and primarily organize the collection and treatment of the most valuable WEEE. The costs of tire recycling is about 7-8 million euros which includes almost all the waste tires. Management of scrap cars does not entail excess costs, since the value of metal from the vehicles covers the waste management expenditures. The producers of all the packaging types (glass, metal, fibres, plastic, wood) have collected about 1,5 million euros for the information system and organization annually and, in addition to that, 3,4 million euros of utilization fees. The data about the costs of producer responsibility system for paper was not available. (Ympäristöministeriö 2010a, 101)

4.4.4 Costs of new collection network for packaging material

As there will be changes in managing of packaging material because of the new waste law (the partial producer responsibility for packaging is turning to full producer responsibility), the Ministry of Environment (Ympäristöministeriö 2010b, 2) estimated the costs of the requirements of the new collection network. There should be reasonable possibilities for all the inhabitants to be able to utilize the regional collection points of packaging material. There were three different models: standard network (1 372 collection points), sparse network (1 014 collection points) or dense network (2 550 collection points).

In the models the collection points need to be emptied so often that there will not be littering or putting the recoverables to the mixed waste containers (emptying every 1-16 weeks depending on the waste sector). For the new collection point, the costs are composed for example of the establishment costs (land, licenses, building, containers), annual costs (investment costs, emptying, maintaining) and administrative and consulting costs. The number of inhabitants in the area effects on the amount of the material collected, emptying times and methods (tables 29-31, appendix 5). It is estimated that the collection point of four waste sectors needs the land area of 62 m². The container for paperboard needs 41 % of that area, plastic 23 %, glass 18 % and metal 18 % (figure 11). (Ympäristöministeriö 2010b, 6-8)

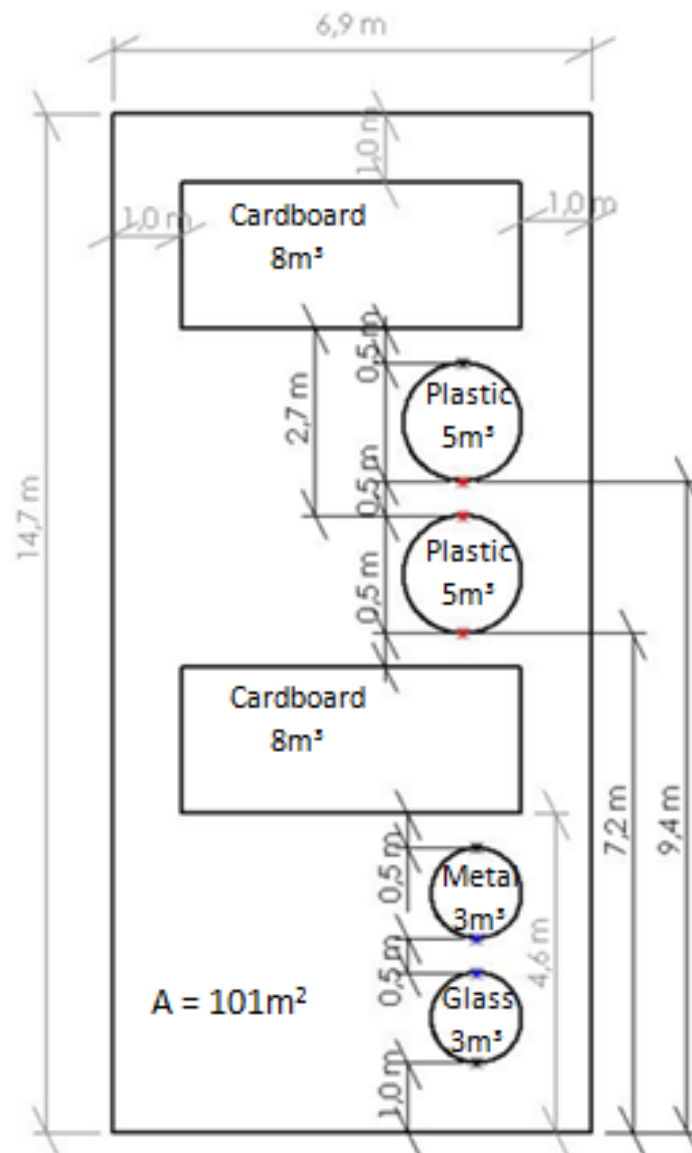

Figure 11. Layout of the regional collection point (Ympäristöministeriö 2010b, 8)

The price of the containers depends on the model of the container (surface or deep collection). In addition, it is estimated that the information board and licenses for one collection point cost about 100 euros and the maintaining and administrative costs are about 90 euros/material/collection point/year. The purchase price for the waste containers depends on the number and size of the container (table 32, appendix 5). (Ympäristöministeriö 2010b, 9)

Usually the land area is rented. In addition, there will be costs caused by the wearing of the land and containers. The emptying costs of the containers depend on the size, type and location of the container and they varies very strongly (from 10 euros to even 160 euros per emptying). The prizes for the emptying are then estimates (table 33). Collected material can be transported to the pretreatment facilities or directly to the utilization plant. Depending on the collection area, some recoverables are used as material or energy. The number of the collection points differs depending on if the collection network in standard, dense or sparse and the numbers of the containers differs depending on the material collected and the number of the inhabitants in the collection area (tables 34-35, appendix 5). The total cost of the collection points depends on the type of the network and the type of the collected material (tables 36-37, appendix 5). The estimate of the costs of the establishment of the one collection point for four waste material is about 11 700 – 13 700 euros. The high establishment cost of the collection point for sparse network is due to the centering of the collection on the large service area. The annual costs vary depending on the network and waste type (table 38, appendix 5) varying from 520 euros to 3 680 euros per waste fraction. Annual costs of collection point for four waste sector is 5 300-6 300 euros per year. (Ympäristöministeriö 2010b, 9-16)

4.4.5 Total costs of waste recovery in Finland

It is challenging to estimate the total environmental and economic cost of waste recovery since there are many issues affecting on the costs. Myllymaa et al. (2008a, b) have made some calculations of those costs for some combustible waste fractions in different kind of areas (infrastructure, location, residential density, waste amounts and fractions, industry in the specific area, etc). In addition, the report takes into account if the recoverables are used for material or for energy, what are the transportation distances, what materials they are replacing and so on (Myllymaa et al. 2008b)

The transportation costs for one tonne of every waste fractions and different transportation distances were calculated based on the weight of the waste load, the travelling distance and the hourly cost of the used vehicle (83 euros). The consumption of diesel was based on the figures from Mäkelä (2002). It was estimated that the speed of the vehicle was about 50 km/h when driving short distances (less than 10 km) and 70 km/h in longer distances (over 10 km). The time for the loading and unloading of one load was estimated to be 30 minutes for loads under 15 tonnes and about one hour if the load was heavier. Also the breaks and refilling was taken into account by using the coefficient 1,15. It was estimated that the weight of one load was 7,4 tonnes for mixed waste, 9,4 tonnes for bio-waste and 24 tonnes for REF (Isoaho 2008 in Myllymaa et al. 2008b, 43-44). The average costs of collection of mixed waste and bio-waste is assumed to be 60 euro/tonne (Motiva 2007, 50-53; Nummela 2007 in Myllymaa et al. 2008b, 43-44)

The establishment price of the small (6 000t/year) barrel composting plant is about 2 million euros and the annual treating cost is almost 100 euro per treated bio-waste tonne (Illikainen 2007 in Myllymaa et al. 2008b). The production of peat mold from the compost pays about 10 euros per output tonne. (Laine 2007 in Myllymaa et al. 2008b) The investment costs of the small-scale anaerobic digester (6 000 tonnes of bio-waste and sludge from waste water treatment) are much lower (about 670 000 euros) and the annual treating costs of bio-waste are just 15 euros/tonne. In addition, it is possible to produce electricity by using anaerobic digester. (Luostarinen 2008 in Myllymaa et al. 2008b) Processing costs in this case are lower than in composting since composting plants use quite sophisticated technique which increases the costs of composting. It needs to be noticed that the main aim of collection and composting of the bio-waste is to produce inexpensive material to replace the peat but for the need of the waste management system. (Myllymaa et al. 2008a, 78, 80) The total annual costs for the landfill depend strongly on the size and the operation time of the landfill. The total annual costs for the landfill with capacity of 450 000 tonnes of waste and operating time 8-10 years are about 29 euros per tonne (Vänskä 2007 in Myllymaa et al. 2008b)

4.4.6 Prices of recoverables on the European market

The price of recycled materials is highly dependent on the price of raw materials and, therefore, by the overall economic development. The prices of recoverables may vary strongly during the years (figure 12).

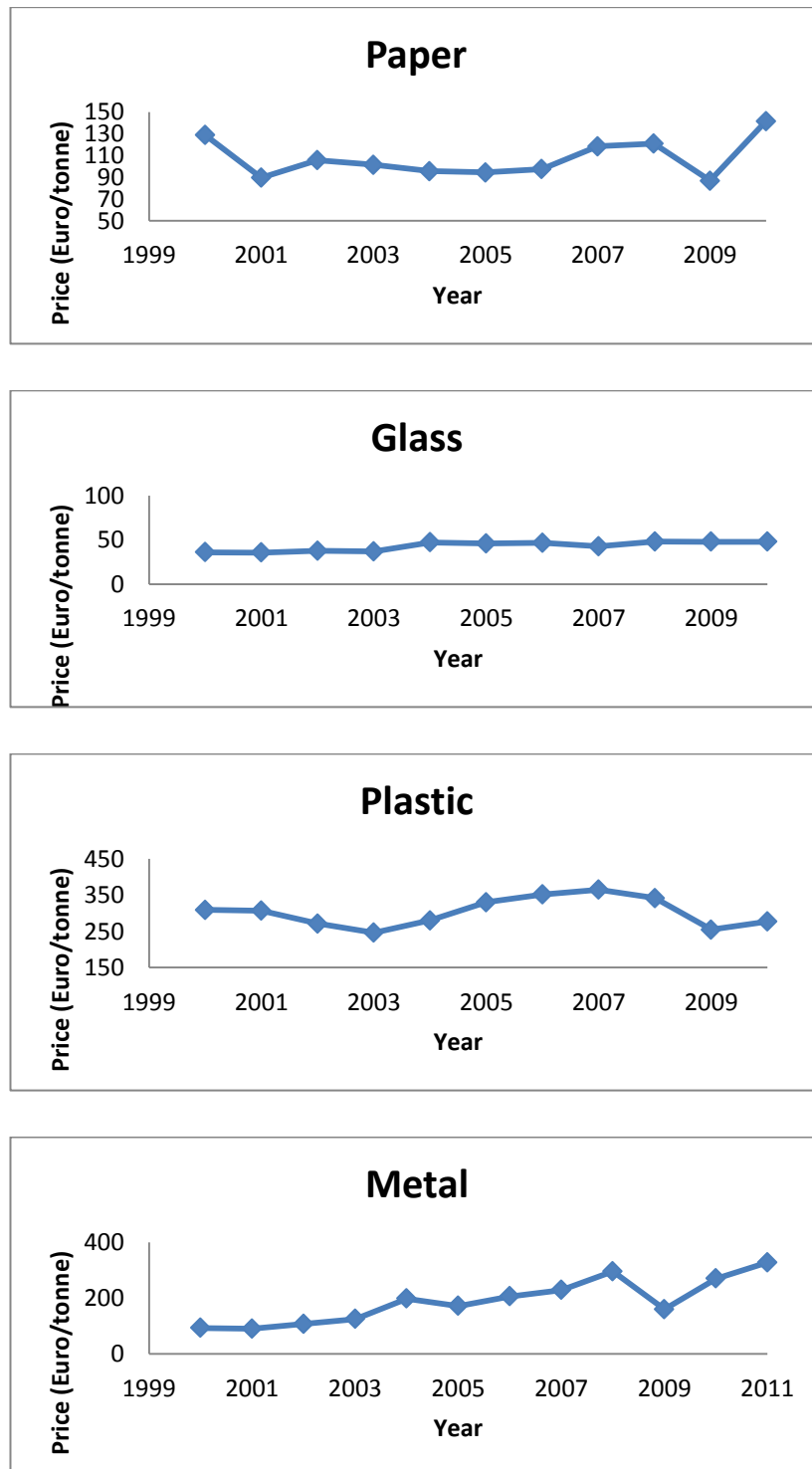

Figure 12. Average prices of recoverables (euro/tonne) in Europe in 2001-2011 (Eurostat 2012; Teknologiateollisuus ry 2012)

The average price for tonne of recycled steel was already 340 euro/tonne in Germany in March 2012. (Teknologiateollisuus ry 2012) The price for recycled non-ferrous metals is not known but it usually is multiple compared to the price of scrap steel (Ympäristöministeriö 2010a, 134). The price for recycled paper depends on the type and quality of the paper. If the paper is well sorted, clean and consist of large amounts of

bleached chemical pulp, the price is higher than average. The price of the waste paper fluctuates strongly depending on the current market situation. As the prices may vary strongly very rapidly, it is extremely difficult to calculate the cost-effectiveness of the investments to using of the recoverables. (Laukala 2011, 6)

4.5 MSWM in the sparsely populated Northern areas – case Lapland

The surface area of the region of Lapland is 100 369 km² which is over one fourth of the total surface area of Finland. The number of inhabitants in that area was only 183 488 in 2010 (3,5 % of Finnish population) which makes population density less than two inhabitants per km², while the Finnish average is 17 inhabitants per square kilometer. The economic structure of Lapland is also different from other areas of Finland: it consists more of primary production and public sector and less of industry and private services than in other areas. (Lapin ELY 2011, 11-12)

4.5.1 The prevalent MSWM system

The progress of MSWM systems has been slower in Lapland than in other parts of Finland. The main reasons for that have been the large area, small amounts of generated waste and the long transportation distances to the waste centers and utilization facilities. In most of the municipalities (13) the waste transportation is organized by municipalities, in seven municipalities it is based on contractual transportation and one have mixed system. The main treatment for MSW in Lapland has been landfilling. In 1992 there were 94 landfills, in 1995 still 55 landfills but in 2007 just 15 and in 2011 only three landfills remain in operation in Rovaniemi, Simo and Tornio. Hence, the transportation distances of the mixed waste may be remarkably long, up to 600 km. The co-operation between municipalities has been improved after year 2000 and the possibilities to sort and recycle have improved e.g. by establishing ekopoints and investing in waste counseling. However, the plans to reduce the total amount of MSW generated and to increase recovery have not been fulfilled. The total amount of MSW was 500 kg/inhabitant and the amount of landfilled waste is still high in Lapland, about 362 kg/inhabitant, when the average amount was 212 kg/inhabitant in 2010 in Finland. The recovery percentage of the MSW was 27 % in Lapland. (Lapin ELY 2011, 13, 39)

In addition to the three waste centers, there are six transfer stations, and 13 separate transfer stations for the pretreatment of recyclables in Lapland (figure 13). In transfer stations, the unsorted MSW is pressed to containers and transported to the final disposal site. In the transfer stations of recyclables the sorted MSW is received and transported to utilization facilities. (Lapin ELY 2011, 19, 21)

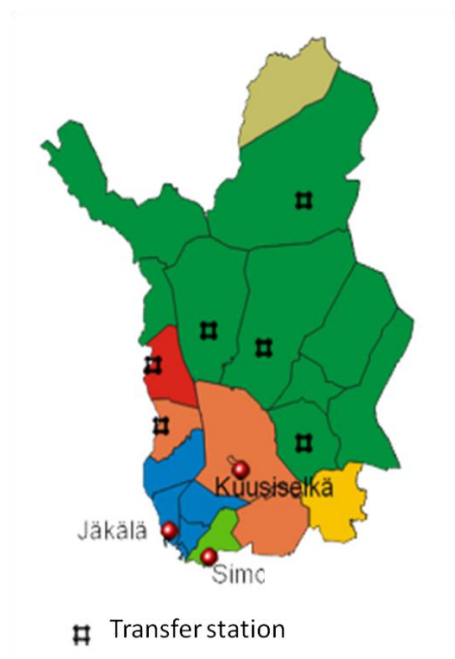

Figure 13. Waste centers (red dots) and transfer stations in Lapland. (Lapin ELY 2011)

4.5.2 MSW recovery in Lapland

In addition to the transfer stations, there are 360 ecopoints in Lapland established by waste management organizations and producer organizations. 100 ecopoints are so called full-service points with containers for glass, paper, metal and paperboard. Bio-waste is collected separately in Rovaniemi, Kemi, Tornio and Ranua city centers from companies, public facilities, and from the largest residential buildings. The amount of collected bio-waste was 4000 tonnes annually, which is estimated to be more than third of the bio-waste produced in Lapland. Some of the waste fractions from sparsely populated are collected by using moving collection events e.g. for oily wastes and hazardous waste. In some sparsely populated areas in Rovaniemi, Ranua and Pello even some household wastes (e.g. furnitures, old clothes, shoes) and small amounts of construction waste are collected by using collection events. (Lapin ELY 2011, 26-27)

There are 18 composting plants of which most are in connection with waste water treatment plants. There are biogas plant established to the old, unused landfill in Rovaniemi that produced about 1,4 million Nm³ of landfill gases in 2009. There are no waste incineration plants in Lapland but in Tornio Outokumpu factory has permission to co-incinerate some waste material (e.g. sorted paper, packaging material and energy waste). The permission is for 36 500 tonnes of waste annually. The primary waste source (90%) would be the waste wood material produced in factory and the rest would be plastic, cardboard and paper that are not suitable for material recovery. The co-incineration has not started yet but for a short trial period. (Lapin ELY 2011, 22)

The amount of biodegradable waste (i.e. waste that can be degraded aerobically or anaerobically such as food items, garden waste, paper, cardboard) in Lapland is estimated to be 44 600 tonnes. The amount of separately collected bio-waste for composting is about 4,56 tonnes, paper and cardboard waste for recycled paper products about 7,68 tonnes and waste wood for incineration about 2,31 tonnes. Some other biodegradable waste fractions are used for making REF and about 1,56 tonnes of energy waste is used for REF as well. About two thirds of the biodegradable MSW is landfilled and small amount is incinerated. (Lapin ELY 2011, 41)

It has been noticed that more and more of waste brought to the waste containers in rest and parking places is mixed MSW especially in municipalities with plenty of holiday houses. The MSW in rest areas causes the fast filling of the containers, increased need for emptying times and therefore increased costs. It is obvious that there are problems in the organization and/or monitoring of the MSW management in Lapland since large amounts of MSW is brought to those public containers (Lapin ELY 2011, 27-28)

4.6 MSWM in a Northern city - Case Oulu

4.6.1 Separate collection of MSW in the city of Oulu

According to the waste management regulations of the City of Oulu, properties are obliged to have collection bin for mixed waste. In addition, residential building with a minimum of four apartments must have separate collection bin for waste paper, cardboard and bio-waste. In addition, residential buildings with a minimum of ten apartments need to have separate collection bins for carton and liquid packages, metal and glass. Other properties, such as office and business premises, industrial properties,

schools and restaurants need to have collection bins for waste paper, bio-waste (if the property has canteen or foodstore), for cardboard (if it is produced over 10 kg/week), for paperboard (if it is produced over 10 kg/week) for glass (if it is produced over 20 kg/week), for waste wood (if it is produced over 20 kg/week), for wood (if produced over 20 kg/week) and for metal waste (if it is produced over 10 kg/week). (Oulun kaupunki 2006, 3-4, 6-7)

Bio-waste needs to be transported to the licensed composting plant or composting area by using organized waste transportation, or it needs to be composted in the property. All the separately collected waste fractions need to be recycled. Small residential buildings are obliged to transport their recyclables to the regional waste collection points and to compost their bio-waste if possible. Recyclables need to be collected separately in public events as well. (Oulun kaupunki 2006, 3-5, 9)

4.6.2 The Oulu Waste Management Company

The Oulu Waste Management Company (Oulun Jätehuolto) is a public-service company of the city of Oulu. It is responsible for waste treatment, coordination of waste transport and waste education and supplementary services. The waste management operations are funded by the fees collected from the delivery of waste to the Rusko Waste Management Centre and funds received from the sale of methane gas produced in waste management centre and from other services. Tax moneys are not used for the operations. (Oulu Waste Management 2012)

4.6.3 Rusko Waste Management Centre

Rusko Waste Management Centre consists of 93 hectares of protected park area of which 5.5 hectares are in use for landfilling of mixed waste and construction waste. (figure 13). The remaining area is for operations such as preparing for re-use stations, hazardous waste storage, composting area and offices. About 300-350 customers visit waste centre every day. Customers can bring their reusable and recyclable domestic waste and hazardous waste to the free recycling station in Rusko Waste Management Centre. (Oulu Waste Management 2012)



1. Landfill for hazardous and special waste
2. Composting plant
3. Composting field for oily soils
4. Treatment plant for liquid waste
5. Composting field for bio-waste
6. Oil station
7. Recycling area: Oivapiste
8. Sorting area for construction waste
9. Scales and customer service premises
10. Sorting facilities for hazardous waste
11. Hall for energy waste
12. Biogas pumping station
13. Landfill
14. Infiltration basin
15. Reception for garden waste and clean timber
16. Administration

Figure 13. Rusko Waste Management Centre (Oulun Jätehuolto 2012a)

The first point in Rusko Waste Centre is the guidance point in which a customer can find parking place, area map and instruction (Oulun Jätehuolto 2012a). Waste with fee is weighed on separate scales since the customers pay according to the weight of the waste. The more harmful the waste is, the more expensive it usually is. (Oulu Waste Management 2012)

Separately collected bio-waste from Oulu and other municipalities is handled in the composting plant. The amount of bio-waste treated in Rusko is about 8000 tonnes annually. (Oulun Jätehuolto 2012a) Rusko Waste Management Centre uses three specially designed composting drums for composting of the collected bio-waste (Oulu Waste Management 2012). Every composting drum is 125 cubic metres of volume. Bio-waste is in the composting drums for one week after which it is transferred to a designated area for maturation. The maturation process lasts 6-12 months, when the material is ready for landscaping. (Oulun Jätehuolto 2012a)

The Rusko landfill produces methane which has been recovered and utilized for over ten years. Methane is used in the Paroc factory, in the Oulu University Hospital and for own heating purposes. One third of the landfill gases is used to produce electricity and the rest two thirds produce heat. Electricity and heat are used in the Rusko Waste Management Centre area. The remaining excess electricity is sold to the national power grid. (Oulu Waste Management 2012)

There are almost 70 recycling stations in Oulu Waste Management's operation region. These stations locate in areas that all residents have adequate possibilities to use them (near the large shopping centres or schools). Recyclables produced in households (e.g. plastic, cardboard, glass, metal and paper) can be transported to these recycling stations. Hazardous waste and small amounts of waste oil from domestic and agricultural activities and electrical and electronics waste are accepted for free. If municipality does not have waste station, local businesses and contractors are responsible to receive hazardous waste matters. (Oulu Waste Management 2012)

Oivapiste is the largest recycling point for recyclables and hazardous materials in Oulu and it is located in the Rusko Waste Management Centre (figure 14). Households are allowed to bring their cardboard, paper, paperboard, plastic, metal, clean and untreated timber, less than one cubic metre of pressure treated timber, packing glass, tires (with and without rims), WEEE, hazardous waste and expanded polystyrene for free. (Oulu Waste Management 2012)

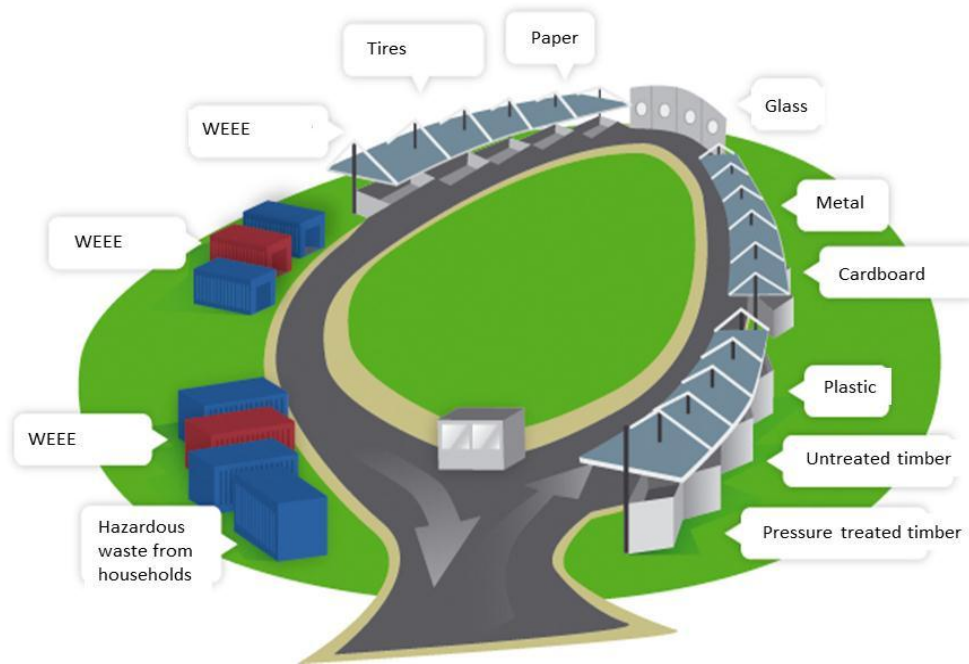

Figure 14. Oivapiste of Rusko Waste Management Centre for the collection of household waste (Oulun Jätehuolto 2012a)

4.6.4 Utilization of recoverables collected in Oulu area

The amounts of separately collected recoverables have increased steadily during the past ten years (figure 15).

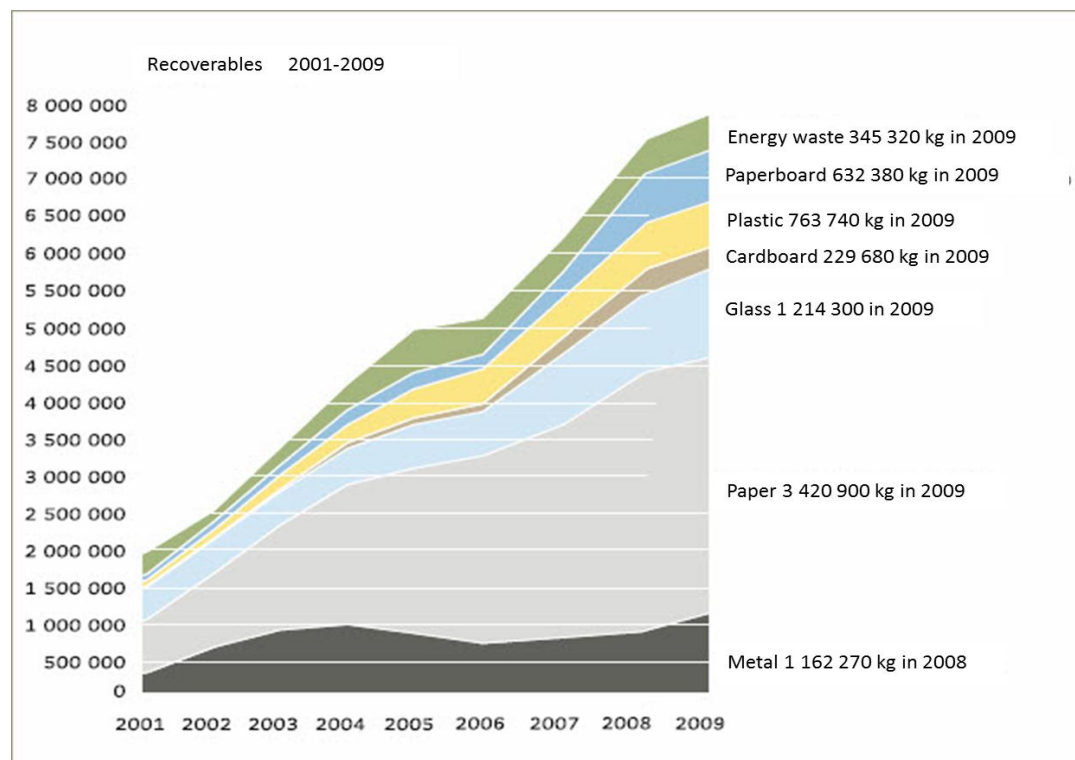

Figure 15. The amount of recoverables generated in Oulu Waste Management operating area. (Oulun Jätehuolto 2012b)

The bio-waste which is composted in Rusko Waste Center is used for landscaping and construction work at the waste centre (Oulun Jätehuolto 2012a). Part of the MSW and waste from industry is used for the production of recovered fuel (REF). Most of REF was earlier used in Kajaani (heating plant of Kainuun Voima Oy) and some of it was transported to Anjalankoski, Kokkola and Pietarsaari. In the future, combustible waste fractions will be incinerated in the Laanila incineration plant in Oulu. (Oulun Jätehuolto 2012a, Illikainen 2012) The collected waste paper is recycled to newspaper, catalogs, toilet paper and kitchen paper whereas cardboard is recycled to coreboard, packing board and corrugated cardboard. Some waste paper is used for the preparation of wood fibre wool. (Turunen et al. 2008, 29). The collected glass is used in the earthworks of Rusko waste management centre (Illikainen 2012). In addition, some of the glass was transported to Forssa to be used as raw material e.g. for the preparation of thermal insulation material. (Turunen et al. 2008, 30). Some of the glass is stored for later use. Metal is used as a raw material in industry (Oulun Jätehuolto 2012a), mostly in the Outokumpu factory in Tornio (Illikainen 2012)

4.7 Waste management in the future in Finland

Decades ago the waste management was quite cheap for municipalities since the only cost was the maintenance of the “dumping place” (Tommila 1984, 376). Nowadays it is very well known that uncontrolled waste dumping pollutes the environment and may cause health problems (Finnish environment institute 2011a). As the amounts of virgin raw materials are limited, the recovery of waste as material or energy is very logical. Due to policy instruments, the infrastructure of waste management and the recovery of wastes have improved in Finland in the 1990s. (Melanen et al. 2002, 13).

The recovery of municipal waste is, in general, well-organized in Finland. Most of the nutrients embedded in MSW are in the organic waste fraction and they are in a form that is easy to utilize but which is also the most liable to leaching or volatilization. (Sokka et al. 2004) Therefore, policies are increasingly addressing the organic waste component of MSW. There is a need to decrease the amount of bio-waste going to landfills and, therefore, the biological treatment and energy use of bio-waste will increase. (Jätelaitosyhdistys 2011 b)

According to the National Waste Plan (Ympäristöministeriö 2008, 9), the primary aim is firstly to stabilize the amount of waste and then reduce the amount of the waste by the

year 2016. Moreover, 50 % of MSW is to be recovered as material and 30 % as energy and only 20% will be taken to landfills. (Sokka et al. 2007)

Although the MSWM system is considered to be at the good level in Finland, the situation in sparsely populated Northern areas is still challenging. The plan for MSW management in Lapland is to reduce the amount of MSW generated by 1% annually. The amount of MSW going to landfilled need to decrease about 30 % by the end of year 2020 by the waste prevention measures, by improving producer responsibility systems, by expanding the separate collection of bio-waste and by treating the bio-waste in the composting or biogas plants. (Lapin ELY 2011, 52)

As the waste taxes are getting higher in future, landfilling may become an unfavourable option compared to energy recovery. As the transportation distances are long in Lapland, increasing fuel prices will make transporting waste for treatment over long distances very expensive. (Lapin ELY 2011, 71-74)

Oulu has very well-established and well-functioning MSWM infrastructure with high reliance on kerbside recovery of recyclables. Oulu is also a hub for the collection of recyclables, some of which are transported over rather long distances for recycling. It is yet to be seen how the situation will change should the combustible fractions be routed for energy recovery.

A general tendency for the whole country is the further reduction of the number of landfills in operation. As well, waste management operators are increasingly interested in moving toward waste incineration. As only large-scale waste incineration plants are feasible, these developments will likely further is decreasing even further and there is need to increase transportation distances. Notwithstanding, the tendency is likely to be the further centralization of waste treatment stations and will increase the need to establish new transfer stations. It is to be hoped that, in the case of bio-waste local utilization possibilities will be explored, such as co-digestion with wastewater sludge and biodegradable industrial wastes.

5. Municipal solid waste management in the Russian Federation

Environmental awareness in Russia has strengthened during the past 20 years. The problems caused by the increased amount of waste have been acknowledged especially in large cities with large number of inhabitants and industrial and commercial activity. (Honkanen et al. 2008, 43) The amount of waste has risen sharply over the last ten years due to the high economical growth (Rodionov & Toshihiko 2011, 1486). It is estimated that the consumption in general and particularly the use of packagings, electrical and electronic equipment and cars is growing and also the amount of MSW is assumed to be increasing. (Honkanen et al. 2008, 43) This trend is quite obvious since the amount of MSW has commonly increased in accordance with increasing consumption enabled by high GNP (Europen 2011).

The MSW in Russian Federation typically consists of paper, cardboard, food wastes, wood, metal, clothes, bones, glass, leather, rubber, stones, polymeric materials and other (non classified components) (EVD 2009, 18). It is estimated that the amount of packagings, glass, bio-waste and small waste fractions in produced MSW will change significantly in future in Russia because there will be new packagings and changes in consumption habits and mechanical treatment of wastes. It is hard to compare the present and future amounts of waste nowadays, since the classification of waste sectors is different (e.g. the construction waste, large waste items and household appliances are not in their own sectors in 2005.) The inaccuracies in the waste amounts in Russia are caused by the fact that the waste loads are usually not weighted at any stage. Waste statistics in Russia are based on norms and are measured in volume. Usually norms are outdated since the amount of waste is strongly increasing. In addition, the waste concepts may be different in Russia and in Europe and Finland. (Honkanen et al. 2008, 46, 60)

The average MSW disposal distance is 20 km and, in big cities, (with population of 500 thousand inhabitants and more) it can be 45-60 km. It is estimated that the waste disposal distance grows 1.5 km every year and the transportation cost increases by 15-20%. This forces to use double-stage waste disposal system with the transfer stations and sorting stations, and large dump trucks. Waste transportation companies taking care of industrial and municipal waste need to have licenses. MSW is handled by both

municipal and private actors and wide range of waste transportation vehicles is used (i.e. there are different kind of mode, capacity, loading mechanism, compressing and dumping system in vehicles). Since transportation costs are high, it may be rational to use double-stage technology i.e. transfer stations and larger dump trucks. It may reduce the number of vehicles and transportation costs even 30 % and lower the emissions from trucks. (EVD 2009, 25, 30-31)

5.1 Waste recovery

Waste management was more in the forefront in the USSR. There were collection points for milk, beer and soft drink bottles, and students and pioneers collected waste paper and scrap metal. Only about 3 % of MSW is recycled in the Russian Federation, whereas up to 10 % of domestic waste and 50% of industrial waste would be recyclable using existing technologies. An important positive change was the formation of Regional associations and unions that acted to organize the Regional production systems and to protect entrepreneurial rights. (EVD 2009, 41-42)

According to the Russian law, the organizing of waste collection and recycling is under the responsibility of local authorities. Source separation and recovery are quite rarely used in Russian waste management system. Separate collection for glass, plastic and paper are organized in some cities but on a very small scale. The lack of recycling opportunities is due to the shortcutting of legislative regulation, absence of strict requirements to separate wastes, weak public awareness and absence of reception stations and market for secondary raw material markets. Usually there are low efficiency in garbage trucks (low compression ratio) and lack of transfer stations and incineration plants. (EVD 2009, 48, 80)

Since source separation is missing, there is a need to maintain separation facilities. Separation facilities are usually within the waste treatment facilities or in the area of landfills. They make profit by purchasing and selling the recoverables (e.g. metal, plastic and glass) which is paid by the industry (e.g. mercury lamp disposal), or by recycling the waste (e.g. aluminum cans, PET-bottles). Many recyclable sectors are unprofitable because of cancellation of tax benefits and absence of clear business criteria in the industry. It is not the treatment of the waste that is unprofitable but the collection and transportation. (EVD 2009, 29, 42)

The low recovering percentage in St. Petersburg is caused by inefficient waste management system without source separation. The aim is to increase the recycling percentage in St. Petersburg. It is estimated that, in 2004, the recovering percentage was 5 %, in 2015 it will be 25 % and in 2025 already 35 %. To achieve these targets, there is a need to establish new transfer, sorting and treatment stations and to renovate the existing ones. Moreover, source sorting and separate collection for MSW (e.g. for hazardous waste, large waste items, recoverables and mixed waste) must be organized. There is intent to increase especially the recovering rate of ferrous and non-ferrous metals, glass, paper, certain plastic types, rubber (e.g. tires), liquid oily waste, wood, textile, organic waste, mineral and synthetic oil and waste containing mercury (e.g. fluorescent light). In 2007 there, was not enough capacity to handle those waste sectors in St. Petersburg. (Loseva 2007)

If the landfilling will continue to be the main disposal method in the Russian Federation, certain waste streams should be recovered before landfilling. Most important fractions are wastes that are suitable for recycling or energy recovery and/or those responsible for greenhouse gas emissions from landfills (e.g. organic or biodegradable waste). (European Commission 2008, 26)

Recoverables can be separated from the waste streams either before the collection (source separation) or after that from mixed waste stream (European Commission 2008, 26). The most complex and expensive way to separate recoverables from mixed waste is to build the specialized plant where most of the secondary material is removed whereas in more simple plants only the undesirable elements are eliminated prior to incineration. One option is to get the public to involve by organizing the collection areas or kerbside collection that inhabitants can be able to use. Source separation for e.g. waste paper, textile, plastic, glassware and metals is very common in many countries. Some cities in Russia have tried source separation (e.g. South Urals, Moscow, St Petersburg) but with no great success. There have been problems due to the deficiency of legislative regulation, lack of awareness of inhabitants, missing of the logistics for source separated waste materials. (EVD 2009, 26-28)

5.2 Recoverable waste fractions

The collection and processing of waste metal is very well organized in the Russian Federation. Ferrous and non-ferrous metals are recovered separately. In August 2009,

the purchase price of waste stainless steel was 1750 USD/tonne in Moscow. The prices for non-ferrous metals were 1500-1900 USD/tonne (quick-speed scrap) and 6000-10000 rubles/tonne (used rolled metal). The amount of produced and consumed glass is increasing in Russian Federation because of the relatively low prices of glass bottles and jars, and their protective properties. Bottles are commonly used for bottling of alcohol and other drinks, food, perfumes and drugs. Earlier in the USSR, the share of recyclable glassware was 85% of the entire consumption rate but, recently, the share was only 40%. The raw material from waste glass can be cullet or fluid glass made of glass sand, limestone, soda and sodium sulfate. Cullet is very cheap on Russian market so the using of it may reduce significantly the production costs. The selling price for the cullet was 1200 rubles and purchasing price 3 150 rubles in 2009. (EVD 2009, 43-44, 52-54; Municipal solid waste 2012 in EVD 2009)

The recovery of waste paper was especially high in the 1970-80's in the USSR. The share of waste paper is about 30% in MSW. The most important waste paper consumers in Russia are paper mills (over 50% of recycled products), package plants and construction materials plants. The purchase price for the waste paper is from 2000 to 3000 rubles/tonne depending on the quality of paper and the area in Russia. Plastic recovery is negligible in the Russian Federation. The present production and consumption of plastic is lower than in many western countries but low recycling rate of plastics (about 13 %) is causing environmental problems. Considering the shortage of polymeric raw materials, waste plastic should be seen as good resource of raw materials and energy. The treatment of plastic is more expensive than the treatment of the regular MSW. The purchase price for the waste plastic is from 8 to 27 rubles/kg and selling price from 5 to 36,5 rubles/kg depending on the quality of plastic and the area in Russia. (EVD 2009, 45-46, 49, 57-58, Municipal solid waste (2012) in EVD 2009)

5.3 Waste treatment

The most common way of waste treatment is disposal on landfill. As much as 90-96 % of all waste generated is still landfilled in the Russian Federation. Most landfills in operation are already overfilled and some of them constitute to environmental and epidemiologic hazards. The waste input to the landfills may be 10-3000 thousand cubic meters per year. Over 1300 solid waste landfills with over 40 thousand hectares of area are used in Russia and about 10% of solid waste is dumped in non-organized places. The area of landfills increases 2.5-4% annually. Most of the landfills are owned by state

enterprises but there are some private waste disposal businesses as well. Problems of landfilling in Russia are lack of landfills, environmental and sanitary standards are often violated in existing landfills, the number of dumps and non-licensed landfills and that many landfills are closed without recovering of the waste. (EVD 2009, 62-63)

In some cities in Russia such as St. Petersburg, there are waste treatment centres where recoverables (like metals) are separated and the bio-waste is composted. In other large industrial cities such as Moscow and Murmansk some of the waste is incinerated. (Honkanen et al. 2008, 54) Whereas in Europe about 2 % of MSW is composted, the share of composting is very small in the Russian Federation. It is estimated that in Russia, the amount of bio-waste from domestic sources is about 50 million tonnes annually and it may be used for biogas production since biogas production potential is high. Because there may be legislative and technical problems in distributing the biogas to external buyers, it may be easier to use the biogas in waste management facilities. It is estimated that only 2 % of MSW is incinerated. Incineration plants may become so expensive that they should be established by private companies. Recovery, recycling and composting may not be in the interests of private owners since they need to have steady amount of waste to run these plants. (EVD 2009, 33, 36-37, 81)

5.4 Future perspectives

Environmental challenges of waste management in the Russian Federation are caused by the absence of reduction or recovery policy for waste, uncontrolled dumping of waste, imperfect treatment of hazardous waste, illegal transboundary movements of waste and hazardous waste (European Commission 2008, 23). The solution of existing waste problems is assumed to be found in economical, legislative and administrative decisions. The most important methods are the principles based on sustainable development according to the EU:s waste hierarchy: prevention of waste, recovery of the waste as material or energy, and disposal only as the final option. (Honkanen et al. 2008, 59). To reduce reliance on landfilling, the best option may be to increase the attractiveness of recycling by using e.g. landfill tax. (European Commission 2008, 28)

While the EU waste legislation is not applicable in the Russian Federation, it can be used as a guideline. It may be useful to start with a step-by-step approach, with concrete milestones in waste management planning. Only after there is already a well-working waste management service with well-managed landfills, the environmental standards of

landfilling and recycling and recovery targets should be considered (European Commission 2008, 29)

Political will is needed to invest in high-level recycling technology and, at the same time, to accept higher waste fees. The attractiveness of secondary products and energy from waste also needs to be improved by economic and legal instruments. Also public campaigns and public procurements should be used to increase the awareness of waste as a valuable resource. (European Commission 2008, 26-27)

EXPERIMENTAL PART

6. Strategic municipal waste management planning

EU legislation requires each Member State to make one or more waste management plans which follow relevant EU directives (European commission 2003, 5). Waste management need to be seen as a matter of public interest regardless of the fact that it may ultimately be carried out by the state itself or private company. According to Art. 5(1) of the WFD, the Member States need to ensure that there is a sufficient network of waste disposal facilities that obey the best available technologies but does not cause immoderate costs. (European Commission 2008, 11) To achieve a reasonable and well-functioning MSW management system, the principles of sustainable development, integrated solid waste management, and the waste management hierarchy must be included and practice at all the possible levels (national, state/provincial/regional, municipal, community, and institutional levels). The governments in each level (from national to municipal) are responsible to make sure that planned activities occur within their own jurisdiction and indicators are used to observe accomplishments. (UNEP 2005)

The role of national government in integrated MSW management is three-fold. First it needs to develop and enact legislation and policies which assist and confirm protection of the environment. In addition, it must establish an agency or department to execute these programs, and to perform essential research and development. The implementation of the MSW programs and activities is usually delegated to lower levels. The role of State/Provincial/Regional government in integrated MSW management should also be three-fold with the difference compared to the National level that the last level would be the regulation of solid waste management practices. This level should directly be part of the planning process for MSWM and they should also promote the research and development and pilot projects in the field. The municipal government is responsible for the realization of municipal MSW programs and facilities within their jurisdiction. The municipal government makes a decision if the municipality is directly involved in providing MSW services or if they are licensing companies to provide these services. All the activities should be in line with legislation, policies, and programs adopted at the National and State/Provincial/Regional levels. (UNEP 2005)

Waste management planning differs substantially at national and local or regional levels. Waste management plans have an important role in achieving sustainable waste management and their main aim is to give a sketch of waste streams and waste treatment options. (European commission 2003, 5-6) Waste management plan should include the data about the type, amounts and origin of waste, the technical requirements, possible special arrangement for particular wastes and suitable disposal sites or facilities. (European Commission 2008, 12)

Strategic planning is necessary so that municipal waste management services meet the demand, are suitable to needs, and are cost-effective. Planning is a continuing process i.e. it runs in cycles and since the service must be evaluated and revised constantly to ensure sustainable improvements to future service coverage and standards. (Worldbank 2001, 3; European commission 2003, 7) The process itself consists of six phases: general considerations, status part, planning part, consultation process, implementation and plan revision (figure 16). (European commission 2003, 7-8).

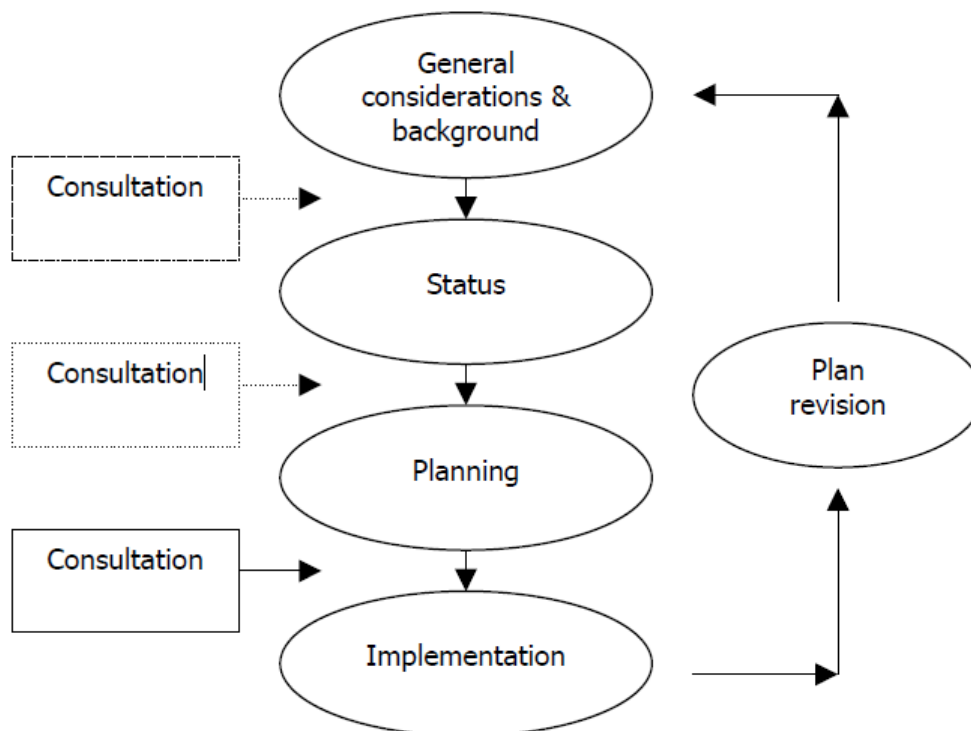

Figure 16. Strategic municipal waste management planning (European commission 2003, 8)

The background part of the waste management plan includes general considerations about the EU waste management principles and expected new EU directives. In the status phase all data and information on the existing situation are collected and

evaluated. A central element of the planning part is determination of political objectives (e.g. select priority waste streams or waste treatment) and to develop indicators to monitor if the objectives are met most effectively. By using consultation process the public should be involved in the selection of waste management system. In implementation phase its orientations are put into practice by legislation, regulation, negotiations with the industry, and/or information to the public. Plan revision is needed before the expiry of the planning period. (European commission 2003, 8-9)

As MSWM is an intensive activity and an essential employer, it may cover 10-50% of a municipal operational budget (usually 10-20% in large cities). It is an essential municipal service that is paid by the customers through taxes and charges. Establishing the brand new MSWM systems and facilities take lot of time and resources (figure 17, Worldbank 2001, 3-4).



Figure 17. The hierarchy of the strategic municipal waste management planning. It is a process of determining needs and priorities and then necessary actions which need to be taken to develop a suitable waste management practices. (Worldbank 2001, 4).

Strategic MSWM planning can be divided into two categories: Strategy and Action Plan (Table 11). The Strategy part displays the overall framework for MSWM systems and standards, and the Action plan part consists of the specific options to be pursued to meet the requirements set on the strategy part. Detailed design work (called Operational planning) is needed to establish the precise arrangements for the implementation of strategic planning. (Worldbank 2001, 4-5).

Table 11. Scope of a Strategic MSWM plan (Worldbank 2001, 5).

Strategy	Action Plan
Overall vision	Pre-feasibility studies for technical options covering:
Goals and objectives (national/areal/municipal)	<ul style="list-style-type: none"> • collection and recycling
National policy framework	<ul style="list-style-type: none"> • treatment and disposal
Development planning framework	Plans covering:
Roles and responsibilities	<ul style="list-style-type: none"> • institutional/organizational development
Waste streams to be covered	<ul style="list-style-type: none"> • service/facilities development
Waste collection targets	<ul style="list-style-type: none"> • financial management and cost recovery
Promotion of waste recycling	<ul style="list-style-type: none"> • public awareness and participation
Waste treatment and disposal policy	Investment plan
Public awareness requirements	Timetable for detailed feasibility study and implementation
Policy on private sector participation	Immediate action plan
Cost recovery and financial management policy	
Outline investment requirements	
Timetable for action planning	

A description of the existing waste collection system and treatment facilities is necessary to achieve an overview of waste streams. Moreover, the description gives data for identifying where improvements are needed. (European commission 2003, 29) Since street sweeping, waste collection and transport are the most visible and noticeable aspects of MSWM to the public, they should receive high political priority. Primary collection means the removal of waste from the properties to a community collection area whereas the secondary collection means the removal of waste from that area to a transfer, treatment or disposal site. In some systems, there is no distinction between primary and secondary collection services. (Worldbank 2001, 29-30).

As most of the efficiency loss in MSWM service occurs when waste is transferred from one part of the system to another, the key is to improve the efficiency of linkages between the different components of the waste collection system. Rationalising operations (i.e. effective management structures, improving workforce productivity and rationalising collection) can produce significant efficiency gains. One important aim should be the elimination of the need for human contact with waste as it results in low operational performance and exposes workers to potential health risks. Moreover, effective and professional systems for segregation, handling and collection of hazardous and infectious wastes need to be arranged since they may cause significant health and safety risks. (Worldbank 2001, 29-30).

After estimating the future amounts of waste and setting the objectives, the implementation of the plans needs to be decided. The action plan may include the selection of collection systems, identification of necessary waste management facilities, assignment of responsibilities to the various parties, considerations of economic consequences and financing and considerations on the use of measures to implement the waste management plan. Collection systems may play an important role in the achievement of recycling targets, so the type of system is very essential. The kerbside collection system is often more expensive but it may also be more effective than regional collection points. In addition to the economic considerations in the decision process, political intentions and environmental aspects need to be considered. (European commission 2003, 37-38)

Recycling is in a critical role in reducing the amount of waste, returning re-usable resources, and minimising the burden of MSWM. Recycling will become more and more important as the amounts of waste increase. It is noteworthy that every tonne of recoverables extracted from the waste stream means a tonne less waste that needs to be managed system. Therefore the most effective waste management systems combine high service standards with high percentage of materials recovery and recycling. In many countries an informal materials recovery and recycling system (e.g. interconnected chain of suppliers, dealers and re-processors) operates alongside the official waste collection service. In Strategic MSWM Plan it needs to be ensured that the growth of the existing recycling system is not hindered. (Worldbank 2001, 29-30). Waste management needs to be organized only by professional actors and any informal waste recycling (e.g. recovering of valuables from landfills or waste bins by non-authorized persons) should be eliminated. (European Commission 2008, 25)

Investments give an opportunity to improve the service performance. For example vehicles and equipment should be suitable to local conditions and roads, and are compatible with existing management systems to ensure that the productivity of the workforce and of the collection vehicles is maximised. Transfer stations may increase the efficiency of MSWM services if round trip travel times from collection areas to the disposal site exceed two hours. In transfer stations collected waste is loaded onto larger haulage vehicles which transport the waste to disposal site. Collection vehicles return to their rounds. (Worldbank 2001, 31-32).

The public (i.e. inhabitants and services) are the major customers of the MSWM service so it is important to get active participation at the community level. When new waste collection methods are implemented, the members of the community should first be consulted about the planned system. (Worldbank 2001, 31).

6.1 Identifying key stakeholders and terms of reference

Various stakeholders and the public should be involved in the planning process to ensure the acceptance of the waste policy plan and commitment to its objects. Political level must accept the need for a plan and allocated sufficient resources to its execution. Participants in the waste planning process cover all the important actors, e.g. representatives from the political and the administrative level, waste experts, representatives from the waste management sector, industry, industrial and commercial organisations, consumer associations and NGOs. (European commission 2003, 21) As political support is needed for the success of the Strategic MSWM Plan, communicating with political leaders and senior decision makers is essential (Worldbank 2001, 6).

In the scope of the MSWM plan the geographical coverage of the plan need to be decided. Moreover, the waste streams, waste producing sectors, collection, transportation and treatment facilities involved in planning must be decided. Also the time horizon, including the possible changes in the future, of the plan is important. (European commission 2003, 19). Terms of Reference (ToR) need to be developed for the Strategic MSWM Plan. Terms of Reference are a document with clear objectives, scope and demands of the strategic planning process, and the responsibilities of stakeholders. (Worldbank 2001, 7).

6.2 Defining the baseline

A baseline study is essential for the identifying the waste quantities and composition and, moreover, understanding existing waste management practices. For that, data and information about waste quantities and composition, existing MSWM operations, institutional/financial framework, predicted future waste quantities and analysis of shortfalls and constraints is needed. The data about waste quantities and composition is needed to decide the demand for collection, transfer and treatment facilities and to establish the recycling and resource recovery possibilities. Waste quantities and composition are measured best by weighing the vehicle loads (e.g. kg/person/day) or by

visual estimates (in m³). If possible, further surveys and observations need to be carried out several times at various stages to find out the seasonal variations in the amount of waste and demand for MSWM system. (Worldbank 2001, 12-14).

In status part, the overview about the existing situation (waste collection and treatment system in physical, financial, and organisational terms) is presented as a reference point. The status report differ from national, to regional and local levels, since at national level summarized data is important, whereas the regional/local status report is more specific (amounts and types of waste generated, the capacity of the plants in the area, characteristic regional/local conditions). The most important parameters for the planning are the waste types and amounts, the geographic origin of the waste and the availability of waste management facilities. If possible, analyzing the decreases and increases in the amount of waste during a year is important to get an idea if fluctuations are occasional or durable trend. Other parameters that effect the planning and future waste amounts are population growth, changes in economic situation, changes in demand for, and nature of, consumer goods, changes in manufacturing methods, new waste treatment methods and effects of policy changes (prevention, minimisation, re-use, recycling). It is impossible to predict the future amount of waste but in order to plan the future investment, several scenarios are good to be set up. (European commission 2003, 26-32)

Waste management operations themselves consist of different subsystems, like waste storage, environment cleansing services, primary and secondary collection, transfer, vehicle maintenance, materials recovery and recycling, treatment and disposal. MSWM plans must be based on existing data, demographics, socio-economic development trends and future levels of service coverage. In addition, increasing waste amounts may have effect on material recovery and recycling. The shortfalls and constraints (i.e. underperforming of service, planning, environmental protection, health safety and cost) in the existing system must be defined. (Worldbank 2001, 14-16) As changes in the number of inhabitants and amounts of waste may change quite fast, it is necessary to consider if the future capacity of waste management facilities is sufficient to achieve the aims in the waste management plan (table 12). It may also be necessary to have long-term considerations about the waste management costs. (European commission 2003, 34)

Table 12. Example how to calculate the trend in household waste. (Worldbank 2001, 16).

Existing data about the area:

Number of inhabitants	I
Service coverage (%)	C_1
Generation rate of MSW (g/day)	W
Total amount = $(I * C * W / 10^6)$	

Estimation of the waste amount after five years

Population (4 % annual increase)	$I * 1,04^5$
Service coverage	C_2
Generation rate of waste (g/day) (2 % annual increase)	$W * 1,02^5$
Total amount after five years = $(I * 1,04^5) * C_2 * (W * 1,02^5)$	

Locally collected data is needed for the proper analysis of the trends in the future waste amounts. Number of inhabitants and the amount of waste can be increasing, declining or staying stable, so the percentages and numbers in equations are not suitable in every case. (Worldbank 2001, 34).

A description of the local system may include the collection equipment, transport logistics, location of treatment plants, transfer/sorting facilities, types of treatment plants, recycling activities, payment schemes and regulation. (European commission 2003, 28)

6.3 Establishing the strategic planning framework

Waste management will operate under the Strategic Planning Framework. The most important role of Strategic Planning is to help key stakeholders not only to solve day-to-day problems but focus also on defining their vision for the future. The boundaries of the plan must be clearly defined (e.g. planning area, period and types of waste). Usually the planning area is the geographical boundary of municipality or municipalities participating the plan. (Worldbank 2001, 18-19).

The time horizon for the plan consists of two parts: plans for immediate action and plans for long-term perspective (European commission 2003, 19). The Strategy usually covers 15-20 years whereas the time horizon of 5 years can be enough for the Action Plan with a detailed Immediate Action Plan only over the first 1-2 years. The types of waste included in their Plan must be decided. Objectives of the plan should cover the main goals and key issues of the Strategic Plan. Targets usually are related to the performance and coverage of MSWM services. (Worldbank 2001, 20).

An acceptable level of MSW service depends on effective management, institutional framework, and the financial resources required for operation, maintenance and investment. The most essential MSWM functions belong to six areas, which are Policy (national/regional government direction, legislation), Planning (determining needs, priorities, actions), Regulator (pollution control), Revenue (collection of taxes and charges), Client (ensuring service is provided) and Operator (providing services). It is important to show a balance between incentives (providing systems that reward compliance) and controls (formal obligations defined either by policy or legislation) in responsibilities. MSWM services are essential to public health and environmental protection. Certain aims of MSWM (provision of service to everyone, improvement of waste disposal practices) are common goods and effective organisation and management is needed for appropriate MSWM system. Private sector participation in MSWM service delivery is one option that may improve the cost-effectiveness of services, since private-sector operators are motivated by the opportunity to get the profit. Competition usually leads to efficiency, transparency of the contracting process causes accountability and effective monitoring of operations. (Worldbank 2001, 25-28).

6.4 Waste Treatment and Disposal

In a regional or local waste management plan is detailed planning for the actual management of waste, also for waste treatment and disposal. Therefore action plan should include suggestions on the type and capacity of waste management facilities. (European commission 2003, 38-39) Waste disposal standards have increased gradually in about 20-30 years. Many waste treatment methods (such as incineration and composting) have been successfully used in high-income countries but in a developing country waste treatment may be a problem. Problems have often caused by over-optimistic assessments of technical, institutional and financial applicability. In all countries, even with high recovery rate, there are significant fraction of the wastes that cannot be treated by any other way but landfilling. (Worldbank 2001, 34-35).

Since methods and costs of collecting and treating of the waste vary, the planning horizon varies from few years to decades, depending on the method. The size of the capacity needs to be optimal so that it can be operated economically with reasonable pay-back time. The minimum planning time for the collection system of MSW is three years, for low technology composting plan five years, for sanitary landfill 10 years and

for incineration plan, high technology composting plan and hazardous waste treatment plan even 20 years. (European commission 2003, 39)

6.5 Financial sustainability

Implementation of waste management plan will typically cause significant investment and additional operating costs in the future. When making the decisions about the new waste management system, the economic consequences (e.g. initial investments and operating costs, the future fees and charges) need to be carefully studied. Also the calculations of the costs of managing tonne of waste may help to compare the average costs in different alternatives (European commission 2003, 41-42).

Economic and financial issues are very essential and important part of strategic planning. Important part of the planning process is the strengthening of the financial policy framework, economic evaluation of studied technical options and alternative strategies, and finally the financial assessment of the preferred Strategic MSWM Plan. Usually the costs for the users of the MSWM service are low in most countries. Householders commonly pay for the service as a part of a general utility service bill, and commercial and industrial customers pay a direct service charge. Therefore there may not be direct linkage between charges and the actual operational costs MSWM in the municipalities. In some countries the income from customers is often so low that it does not cover even basic operation and maintenance costs. (Worldbank 2001, 39).

The aim of the economic analysis is to evaluate which technical options or strategies may meet the needed objectives at the least cost to the customers of the MSWM service. It is a tool to compare alternative options for developing the MSWM system by identifying both the greatest net benefit to society (cost-benefit analysis) and at least cost to society (cost-effectiveness analysis). The most important goals of the financial analysis are to demonstrate the financial feasibility of the strategy; to make a financing plan to meet the investment expenditures during the implementation phase; and to make sure that financial resources are available to cover all the financial requirements and obligations in the future. (Worldbank 2001, 41).

6.6 Public awareness and participation

The public (i.e. major customers of the MSWM service) rarely knows what happens to their waste after collection (Worldbank 2001, 42). It is essential to consider which action will change people's behaviour in the most efficient way. Moreover, it is important to think not only the reducing of the environmental pressure but also the economic and political consequences of the actions. Sometimes the best option will be regulatory measures (e.g. when avoiding the spreading of dangerous substances) whereas economic incentives (e.g. taxes, charges/fees) may be more effective for reducing the production of waste or increasing the recovering rate. One more option is the public awareness raising. (European commission 2003, 42)

Public awareness can be increased for example by Stakeholder Participation, Public Consultation, Public Awareness and Education Programme and Public Awareness Campaigns. Increased awareness may cause new demands for improved MSWM services. If public is satisfied with MSWM services, there may be a steady increase in willingness to pay for these services. The main objectives of the awareness campaigns are to provide information for the inhabitants, to achieve public support, to build the profile of SWM and to reduce the amounts of waste. (Worldbank 2001, 42) For instance, the public consultation on a draft of MSWM plan may be a part of awareness-raising activities. (European commission 2003, 23)

6.7 Preparing and implementing the plan

In final stage of the Strategy major decisions with milestones need to be made. First the range of options available to meet the requirements of the Strategy must be evaluated. After the political approval on the Strategy, more detailed work can proceed. The plan can have important political, institutional, technical and financial implications. Immediate actions show the commitment of the municipality to improving MSWM services. In Immediate Action Plan are measures that are simple and cost-effective to launch. (Worldbank 2001, 47-48)

Status part of the MSWM plan is a base for the objectives of the plan at the national, regional and local levels. Objectives should be in balance between waste amounts and treatment capacity by limiting the generation of waste, increasing recycling and recovery or enlarging treatment capacity. Targets for the priority waste streams,

management options and waste sources are needed. The principles of the waste hierarchy should be reflected in the national, regional and local waste management plan (European commission 2003, 35) The goal of the strategic planning is to generate a practical plan which will *make a difference* in practice when implemented. Its true impact is in improving MSWM services at the ground level. It is important that the implementation of the plan is reviewed at regular interval and that changes needed are made. (Worldbank 2001, 50-51)

7. Planning of a sustainable MSWM strategy for the city of Kostomuksha

7.1 Background part

At the moment, landfilling is the only option for treating the MSW, so the planning needs to start from the very basic level, by establishing the collection point system for recoverables. (For the description of the city of Kostamuksha, see Chamilos 2011, page 51)

7.2 Status phase

7.2.1 Existing situation

The population of the city of Kostomuksha is estimated to be 30 000 persons. The number of inhabitants has been quite stable during the 30 years the city has existed. The amount of MSW produced in Kostomuksha is 10 960 tonnes annually, which makes 365 kg per person. (Potapova 2012) The amount of municipal solid waste produced in the Russian Federation is estimated to be 440 kg per person annually so the amount of waste produced in Kostomuksha is less than the average in Russia. According to OECD (2011), the Russian Federation is one of the countries in which the amount of waste per capita varies the most. Hence, the figure from Kostomuksha is plausible.

There is no recycling or recovery of MSW in Kostomuksha at the moment and the composition of waste has not been studied. According to Chamilos (2011, 55, 63), private entrepreneurs take care of waste collection and separating some of the paper and other valuables. Chamilos proposed the separation of bio-waste from MSW in Kostomuksha, since it would help the recovery of 'dry' recyclables. After successful bio-waste separation and data collection about waste composition, it is easier to find the recipient facility and to establish collection system for other recoverables as well. Since there is no data about the composition yet, only estimations can be used.

7.2.2 Estimating MSW amounts in the future

The composition of the Russian MSW is a bit different than in Europe and it was estimated according to the statistics found in the literature. The most reliable estimate was found from the presentation of Loseva (2007) since it is based on the studied MSW in the waste center of St. Petersburg. Composition and daily amount of different waste

fractions were calculated using the estimated 365 kg per person waste amount and the waste percentages of Loseva (2007). The numbers are rough estimates but they are helpful to plan the network of the collection system for Kostomuksha (table 13).

Table 13. Estimates of the amounts of different fractions of MSW in Kostomuksha. (Percentages are from Loseva 2007, MSW amount from Potapova 2012)

Amount of MSW per inhabitant	Percentage	kg/year
Paper and cardboard	20 %	73
Bio-waste (food)	18 %	65,7
Plastic	12 %	43,8
Ferrous metals	4 %	14,6
Non-ferrous metals	1 %	3,65
Glass	10 %	36,5
Stones, bones, ceramics	9 %	32,85
Leather, rubber	1 %	3,65
Wood	4 %	14,6
Textile	5 %	18,25
Garden waste	1 %	3,65
Waste from treatment	10 %	36,5
Other	5 %	18,25
Total	100 %	365

Future amounts of wastes after five, ten and twenty years were calculated (table 14) based on the information about Kostomuksha from Potapova (2012) and by using the equation from the MSWM guide from Worldbank (2001) (see table 12 in chapter *Defining the baseline*). The population was estimated to be 30 000 both from 2012 to 2032, since the number of inhabitants is not fluctuating strongly. The current amount of MSW is 10 960 tonnes/year. It is estimated to be increasing since the economy, which is one factor affecting the amount of goods and waste produced, of the Karelian area is not regressing as the GRB is not declining but rather rising or at least staying quite stable (figure 18). It is estimated that the amount of waste is increasing 2 % per year for the whole twenty year period. The present service coverage in Kostomuksha is not known but it is estimated to be 70 % in 2012 and increasing to 90 % in 2032.

Table 14. Amount of waste produced in 2012 and estimate of waste amount in 2017 (Potapova 2012, Worldbank 2001).

Kostomuksha	
2012	
Population	30 000
Amount of MSW	10 960 tonnes/year
Service coverage	70 %
Amount of MSW	365 kg/capita/year = 1 kg/capita/day
Total amount	$(30\,000 * 0,7 * 1000g/10^6) = 21\text{ tonnes/day}$
2017	
Population (no change)	30 000
Service coverage	80 %
Amount of MSW	$1000 * 1,02^5 = 1104g$
(2% annual increase)	
Total amount	$(30\,000 * 0,8 * 1104g/10^6) = 26,5\text{ tonnes/day}$
2022	
Population (no change)	30 000
Service coverage	80 %
Amount of MSW	$1000 * 1,02^{10} = 1219g$
(2% annual increase)	
Total amount	$(30\,000 * 0,8 * 1219g/10^6) = 29,3\text{ tonnes/day}$
2032	
Population (no change)	30 000
Service coverage	90 %
Amount of MSW	$1000 * 1,02^{20} = 1486g$
(2% annual increase)	
Total amount	$(30\,000 * 0,9 * 1486g/10^6) = 40,1\text{ tonnes/day}$

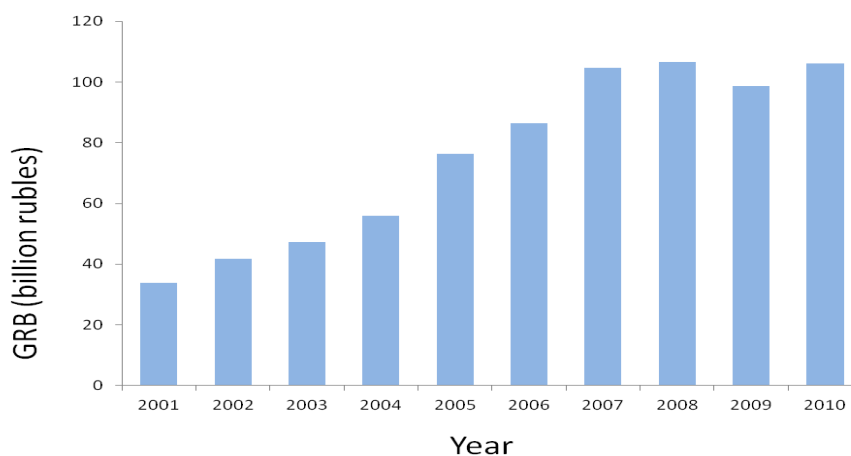

Figure 18. Gross Regional Product of Karelia (billion rubles). (ArcticStat 2012, Official Karelia 2012)

If the service coverage percentage of MSW management were 70 % in 2012 (estimate), the amount of MSW collected would be 21 tonnes per day which is 7 665 tonnes annually. In 2017, with increased amount of waste and service coverage of 80%, the amount of collected waste would be 26,5 tonnes per day (9 673 tonnes annually) and 29,3 tonnes/day (10 695 tonnes annually). After 20 years and with 90% service coverage the MSW amount would be 40,1 tonnes per day (14 636 tonnes annually). The annual amounts of waste for 2012, 2017, 2022 and 2032 (table 15) show the estimated increasing trend in waste production.

Table 15. The amounts of MSW fractions produced in 2012, 2017, 2022 and 2032.

Waste fraction (kilos/day)	Percentage	2012	2017	2022	2032
Paper and cardboard	20 %	4200	5300	5860	8020
Bio-waste (food)	18 %	3780	4770	5274	7218
Plastic	12 %	2520	3180	3516	4812
Ferrous metals	4 %	840	1060	1172	1604
Non-ferrous metals	1 %	210	265	293	401
Glass	10 %	2100	2650	2930	4010
Stones, bones, ceramics	9 %	1890	2385	2637	3609
Leather, rubber	1 %	210	265	293	401
Wood	4 %	840	1060	1172	1604
Textile	5 %	1050	1325	1465	2005
Garden waste	1 %	210	265	293	401
Waste from treatment	10 %	2100	2650	2930	4010
Other	5 %	1050	1325	1465	2005
Total (tonnes/day)	100 %	21	26,5	29,3	40,1
Total (tonnes/year)		7665	9672,5	10694,5	14636,5

To consider the organization on the collection network and the amounts of collection bins, the weekly amount of recoverables and waste need to be estimated (table 16). The calculation of the weekly amounts are based on the numbers estimated in table 15 for year 2012 (30 000 inhabitants, 70% service coverage, MSW amount 1kg/week/person).

Table 16. The weekly amounts (tonnes) of different MSW fractions for recovery.

Amount of MSW per week (tonnes)	Percentage	2012	2017	2022	2032
Paper and cardboard	20 %	29,4	37,1	41,0	56,1
Bio-waste (food)	18 %	26,5	33,4	36,9	50,5
Plastic	12 %	17,6	22,3	24,6	33,7
Ferrous metals	4 %	5,9	7,4	8,2	11,2
Non-ferrous metals	1 %	1,5	1,9	2,1	2,8
Glass	10 %	14,7	18,6	20,5	28,1
Stones, bones, ceramics	9 %	13,2	16,7	18,5	25,3
Leather, rubber	1 %	1,5	1,9	2,1	2,8
Wood	4 %	5,9	7,4	8,2	11,2
Textile	5 %	7,4	9,3	10,3	14,0
Garden waste	1 %	1,5	1,9	2,1	2,8
Waste from treatment	10 %	14,7	18,6	20,5	28,1
Other	5 %	7,4	9,3	10,3	14,0
Total (tonnes)	100 %	147	185,5	205,1	280,7

The estimates of the needed regional collection waste management network can be based on the calculations presented in the chapter *Costs of new collection network for packaging material*. The suitable year for the consideration would be 2017 since it is quite suitable time for the establishment for such network and the waste amounts seem to be quite realistic.

In 2017, the largest produced MSW fraction is paper and cardboard (37,1 tonnes) and the amount of bio-waste is almost the same (33,4 tonnes). Other large fractions that would be suitable for recovering are plastic (22,3 tonnes), glass (18,6 tonnes) and metals (ferrous (7,4 tonnes) and non-ferrous metals (1,9 tonnes)). Other waste groups are not easily recovered and it would be hard to find reasonable use for some of them. Stones, bones and ceramics and waste from treatment are probably not recoverable.

To be able to plan the collection network, there is a need to estimate the produced amounts of recoverable waste fractions in volumes (table 17, conversion factor from Ympäristöministeriö 2010b) to be able to estimate the number of containers needed.

Table 17. The weekly volumes (m³) of different MSW fractions for recovery.

Amount of MSW per week (m ³)	2012	2017	2022	2032
Paper and cardboard	735,0	927,5	1025,5	1403,5
Plastic	504,0	636,0	703,2	962,4
Ferrous metals	29,4	37,1	41,0	56,1
Non-ferrous metals	7,4	9,3	10,3	14,0
Glass	49,0	61,8	68,4	93,6

7.3 Planning part

7.3.1 Establishment of an MSW management system

In this thesis, the planning of MSW management system in Kostomuksha is based purely on data and prices found in the literature and internet. Most of the data is collected from Finnish experiences since there are no functioning MSW systems with functioning recovery of waste materials in the Russian Federation. It is known, that some of the figures presented e.g. for the establishment of the collection points (chapter *Costs of new collection network for packaging material*), the prices of recovering the waste material (chapter *Total costs of waste recovery in Finland*), prices of recoverables (chapter *Prices of recoverables on the European market*) are calculated only for specific situations and they may not be perfectly suitable for the situation in Kostomuksha. However, these figures are good basis to start the planning, but it need to be remembered that they may add bias to the calculations.

At the moment, there are no collection points for recoverables in Kostomuksha. The collection for recoverables can be organized in regional collection points or as a kerbside collection. The central area of Kostomuksha is quite centralized, so also the regional collection points may serve very effectively if their location is suitable. At the beginning, it is good to use transferrable containers to find the most suitable and well-functioning places for collection. Another option is to establish more numerous but smaller kerbside collection points because there are a lots of apartment buildings in the area. Usually kerbside collection is estimated to be more expensive but, on the other hand, it may be more effective in waste recovery.

Most commonly recovered MSW factions in Finland are paper and cardboard, bio-waste, glass and metal, so recovering of those waste sectors is very reasonable also in Kostomuksha as they are major waste fractions. The recovery of plastic depends

strongly on its volumes and the fact if there is a possibility to use plastic as material or energy. The calculations of the establishment of regional collection point described in chapter *Costs of new collection network for packaging material* are based on collection of four waste fractions, which usually are paperboard, plastic, glass and metal. As those waste fractions are the largest in Kostomuksha, it is justified to base the calculations to those fractions. In addition, it is not very realistic to assume that people would take the bio-waste to centralized collection points because of its moist texture and odor problems, therefore, bio-waste collection is best establish as a kerbside collection. The number of the needed containers depends on the number of emptying times and also the number of collection points that is possible to establish in Kostomuksha. If the containers are surface containers, the collection points are quite easy to establish and move, if necessary. In addition, purchasing surface containers is more economical than the buying deep collection containers not to mentioned the special collection vehicle needed for their emptying. The volume of the surface containers usually is smaller than in deep collection containers so they need to be emptied more often.

After the recoverables have been collected from regional collection points or from kerbside collection, they need to be taken to the transfer stations if there are no utilization possibilities near the city of Kostomuksha. It would be reasonable to establish some kind of aerobic composter or anaerobic digester near Kostomuksha, since the weekly amounts of collected bio-waste is 33,4 tonnes in 2017. Paper, cardboard and plastic are valuable materials for recycling but if that is not possible in the area, it would be reasonable to use it for energy recovery. If that is not possible either, the recycling should be centralized to a more densely populated area. In this plan, it is suggested that the utilization of recoverables is considers in the industries of the city of Petrozadovsk. Also building of a transfer station near Segezha, would be sensible considering transport logistics (see map in figure 22, appendix 6).

7.3.2 Scenarios for the establishment of MSWM system in Kostomuksha

There are five different Scenarios considered with different presumptions (table 18). Scenario 1 is based on the idea that all the possible recoverables presented in table 16 (Loseva 2007) will be collected and utilized as material or as energy. The amount of landfilled MSW is then quite small. Scenario 2 is based on the assumption that the collection is not very effective right from the beginning and the amount of collected

recoverables is only half of the possible amount presented in Scenario 1. Hence, the number of collection points are smaller and the amount of landfilled MSW bigger. Scenario 3 is based on figures presented in the report of Ympäristöministeriö (2010b) which was used in Finland when calculating the amount of recoverables when establishing collection points. As the amounts of collected recoverables are quite small, the amount of landfilled MSW is high. Scenario 4 is based on the experiences in Arkhangelsk where there was the separate waste collection experiment in 2005 (Koivisto 2006). These values may be comparable to the situation in Kostomuksha when the differences in population are taken into account. Scenario 5 considers that all waste is landfilled in 2017, which is the situation of the baseline.

Table 18. Scenarios for Kostomuksha.

	Scenario 1	Scenario 2	Scenario 3	Scenario 4	Scenario 5
Based on	Maximum recover (table 16, Loseva 2007)	Half of maximum recover (table 16, Loseva 2007)	Finnish experiences (Ympäristöministeriö 2010b)	Russian experiences (Koivisto 2006)	No recovering, (existing system in 2012)
Amount of collected recoverables	High	Moderate	Low	Low	None
Amount of landfilled waste	Low	Moderate	High	High	All

The calculations in the Scenarios are based on the data from Kostomuksha, found in literature and gathered from other sources (tables 19 and 20). The number of collection points in all the Scenarios was usually based on the amount of the largest waste fraction i.e. paper and cardboard. The container of paper and cardboard was emptied daily or several times per week and the other containers less frequently.

The volumes of the containers in one regional collection point are as in the figure 11 ($2 \cdot 8 \text{ m}^3$ for paper and cardboard; $2 \cdot 5 \text{ m}^3$ for plastic; 3 m^3 for metal and 3 m^3 for glass) and the volumes in kerbside collection points are 1 m^3 for paper and cardboard and plastic and $0,6 \text{ m}^3$ for metal and glass. The *number of containers* needed in every Scenario was calculated by using volumes of containers and the estimation of the future waste volumes (table 20) The *establishment costs* of collection points were calculated by using the information about purchasing price of containers (table 19). However, according to the report of the Ministry of Environment (2010b), by buying large

amounts of containers and by using competition bidding, the savings may be even 30% of the costs, which was used in calculation. The *annual maintenance costs* of collection points are caused by wearing, cleaning, repairing and administration of the collection points and were calculated by using the information about average maintaining costs (table 19).

As the emptying times varies in different Scenarios, *annual emptying costs* need to be calculated separately for every Scenario by using the emptying price for the container of recoverables in table 19 and emptying times in table 20. In the report of Myllymaa et al. (2008b), it was assumed that the recoverables are emptied straight to the vehicles that transfer them to the transfer stations so there should not be local transportation costs in regional collection points. The annual emptying costs (including transportation) of mixed waste and bio-waste was calculated by using the weight based emptying costs (table 19). The *annual costs of treating* the waste material was calculated by using the average treating prices for bio-waste tonne and mixed waste tonne (table 19). The price for treating of bio-waste differs if the bio-waste is treated in composting plant or in the anaerobic digester (table 19).

The *annual transfer costs* of the recoverables from Kostomuksha to Segezha and Petrozavodsk were calculated by using the information of waste loads, transfer capacities and consumption of vehicles, driving distances, loading and unloading times, hourly costs of vehicles and coefficient for breaks and refilling (tables 19 and 20). The average speed of the vehicle for the whole trip would be 70 km/h, the loading and unloading of the vehicle would take one hour and because of the breaks and refilling the transportation time should be multiplied by 1,15.

The annual selling price of recoverables in material use option (paper and cardboard in Segezha and other dry recoverables in Petrozavodsk) was calculated by using the selling price of material/tonne and the amount of collected material (tables 19 and 20). The exact share of paper in the fraction of paper and cardboard is not known but it was estimated to be 75 %. As the prices of the waste materials fluctuate very rapidly according to the market situation, the latest EU prices are used (figure 12). In energy use option produced waste plastic and waste paper and cardboard could be used as a fuel in the industry producing district heat for the city of Kostomuksha. As the price for the REF is assumed to be negligible, there would not be any monetary benefit of providing the waste for the incineration but the using of recovered material as energy

save the costs of landfilling. The selling price of the produced compost (about 1/3 of the original volume) and the production of electricity from the treating of the biomass was calculated by using the information of the original amount of bio-waste and production and price of the electricity (tables 19 and 20)

Table 19. The general assumptions in Scenarios

Year	2017
Population in Kostomuksha	30 000 (Potapova 2012)
Service coverage	80 % (used in Scenarios 1 and 2)
Utilization facilities	In material use Segezha for paper and cardboard; Petrozavodsk for plastic, metal and glass; Kostomuksha for bio-waste. In energy use Kostomuksha for paper, cardboard and plastic. Other fractions same than in material use
Transfer stations	In material use Segezha for plastic, metal and glass
Distances	Kostomuksha-Segezha 241 km Segezha-Petrozavodsk 256 km
Amount of generated MSW	1104g/day/person; 80% coverage 9672,5 tonnes annually (used in Scenarios 1 and 2)
Composition of MSW	Calculated using the statistics by in Loseva 2007 (table 16) (used in Scenarios 1 and 2)
Regional collection point	For four waste fraction, general layout in figure 11 (Ympäristöministeriö 2010b)
Volumes of containers in one regional collection point	2 * 8 m ³ for paper and cardboard; 2 * 5 m ³ for plastic; 3 m ³ for metal; 3 m ³ for glass (Ympäristöministeriö 2010b)
Size of bio-waste container in kerbside collection	240 liters (based on chapter <i>Collection</i>)
Emptying times of containers	Varies depending on the filling of containers
Price for emptying of the containers	For paper and cardboard 30 euros; for plastic 15 euros; for metal 25 euros; for glass 20 euros; for biomass 7 euros For mixed waste 6,5 euros (Ympäristöministeriö 2010b)
Establishment costs of one regional collection point	12 700 euros (average of the report of Ympäristöministeriö (2010b))
Annual costs of maintaining regional collection point	90 euros per material per regional collection point (Ympäristöministeriö 2010b)
Annual costs of maintaining one mixed waste/bio-waste container	10 euros/container
Purchasing price for one bio-waste container (240 liter)	97 euros (Lassila&Tikanoja 2012)
Purchasing price for one mixed waste container (600/1000 liter)	358 euros/450 euros (Lassila&Tikanoja 2012)
Transportation costs of bio-waste and mixed waste	60 euro/waste tonne (see Myllymaa et al. 2008b)
Transportation costs of	Hourly cost of the vehicle 83 euros;

other recoverables to transfer stations	coefficient 1,15 for breaks and refilling; consumption of diesel 0,014kg/km/waste tonne for 24 tonnes/load and 0,011kg/km/waste tonne for 40 tonnes/load; time for loading and unloading 1 hour, price for diesel 0,77 euro/liter. Consumption of empty vehicle 20 liters/100km for smaller (24 tonnes) and 25 liter/100km for bigger (40 tonnes) vehicle. (see Myllymaa et al. 2008b)
The price for treating the bio-waste	100 euro/bio-waste tonne in small-scale composting plant; 15 euro/bio-waste tonne in small-scale anaerobic digester (see Myllymaa et al. 2008b)
The price for treating the landfilled waste	29 euro/tonne (see Myllymaa et al. 2008b)
The selling price for the compost	10 euro/tonne (see Myllymaa et al. 2008b)
The selling price of waste material for material use	For paper 142 euro/tonne; plastic 277 euro/tonne; metal 328 euro/tonne; glass 48 euro/tonne (Eurostat 2012; Teknologiateollisuus ry 2012)
The selling price for waste material for energy use	The price for REF fuel is estimated to be 0 euro/tonne (Ympäristöministeriö 2010b)
The production of electricity from bio-waste	260 KWh/biomass tonne (Raimovaara 2004)
The price for electricity	34 euro/MWh (Nord Pool Spot 2012)

Table 20. Figures for Scenarios 1-5.

	Scenario 1	Scenario 2	Scenario 3	Scenario 4	Scenario 5
Collected weekly amounts (m³) of					
-paper and cardboard	927,5	464	80	68	
-plastic	636	318	5,7	8,81	
-metal	46,4	23,2	0,65	2,38	
-glass	61,8	30,9	3,3	3,75	
-bio-waste	111	55,5	11	11	
-mixed waste	648+352	1123+352	1 726	1 726	1 761
Number of regional collection points with containers for paper and cardboard (2*8m ³), plastic (2*5m ³), metal (3m ³) and glass (3m ³)	20	10	2	2	
Emptying times per week					
-paper and cardboard	3	3	2	2	
-plastic	3	3	0,25	0,5	
-metal	1	1	0,125	0,5	
-glass	1	1	0,5	0,5	
Establishment costs (euros)	254 000	127 000	15 320	15 320	
Emptying costs (euros)	327 600	163 800	14 600	16 380	
Maintaining costs (euros)	7 200	3 600	720	720	

Number of kerbside collection points with containers for paper and cardboard (1m ³), plastic (1m ³), metal (0,6m ³) and glass (0,6m ³)	133	67	10	10	
Emptying times per week					
-paper and cardboard	7	7	7	7	
-plastic	5	5	0,5	1	
-metal	0,5	0,5	0,111	0,5	
-glass	1	1	0,5	1	
Establishment costs (euros)	150 450	75 225	11 312	11 312	
Emptying costs (euros)	606 879	303 440	27 430	32 110	
Maintaining costs (euros)	5 320	2 660	400	400	
Transfer times per year (to Segezha/to Petrozavodsk)					
-paper and cardboard	80 / 0	40 / 0	7 / 0	6 / 0	
-plastic	48 / 29	24 / 15	1 / 1	1 / 1	
-metal	20 / 12	10 / 6	1 / 1	1 / 1	
-glass	40 / 24	20 / 12	3 / 2	3 / 2	
Costs of transfer in material use (euros)	222 021	111 011	14 032	13 175	
Costs of transfer in energy use					
-metal and glass	85 152	42 576	6 239	6 239	
-paper, cardboard and plastic	185 280	92 640	10 710	9 480	
Number of kerbside collection points (euros) with container for bio-waste (0,25m ³)	133	67	13	13	
Emptying times per week	4	4	4	4	
Establishment costs (euros)	9 031	4 515	903	903	
Emptying costs (euros)	104 220	52 110	10 422	10 422	
Maintaining costs (euros)	1 330	665	133	133	
Treating costs in composting plant (euros)	173 700	86 850	17 370	17 370	
Treating costs in anaerobic digester (euros)	26 055	13 028	2 606	2 606	

Number of containers for mixed waste (0,6m ³)	1 080+587	1870+587	2 836	2 835	2 936
Emptying times per week	1	1	1	1	1
Establishment costs (euros)	Existing	Existing	Existing	Existing	Existing
Emptying costs (euros)	267000+145080	462300+145080	700 674	700 560	725 460
Maintaining costs (euros)	10 800+5 870	18 700+5 870	28 360	28 350	29 360
Treatment costs (euros)	129050+70122	22345+70122	338 659	338 604	350 639
Selling price of recoverables (euros)					
-paper	205 474	102 737	17 892	8 066	
-plastic	321 320	160 660	2 909	4 432	
-metal	158 752	79 376	2 263	8 134	
-glass	46 416	23 208	2 592	2 808	
-bio-waste (compost)	5 790	2 895	579	579	
-bio-waste (compost and biogas)	21 145	10 573	2 115	2 115	

The current situation

The current situation of MSW management system in Kostomuksha is that nothing is recovered. The prices of the mixed waste containers are not estimated since there already are containers for mixed waste. The amount of generated MSW is 10 960 tonnes (132kg/m³, Lahdelma 2002, 20) which is 83 030 cubic meters. The treating of landfilled waste in the existing system is estimated to costs about 317 840 euros annually and, similarly, transportation costs make up to 657 600 euros annually. The estimation of existing amounts of containers is 2 661. The costs of maintaining the containers would be 26 610 euros altogether/year. The estimates of annual costs are then 1 002 050 euros for the existing system.

Scenario 1 (maximum recovery)

Scenario 1 is based on the maximum waste amounts that were calculated in table 16 for the year 2017. In that case there will be 30 000 inhabitants, 80% service coverage and generated MSW amount 1104g/week/person and all the inhabitants would recover all the possible waste fractions. The weekly volumes of recoverables are then paper and cardboard 927,5 m³, plastic 636 m³, metals (both ferrous and non-ferrous) 46,4 m³ and glass 61,8 m³ (based on data from Loseva 2007 and Potapova 2012).

Regional collection points of the recoverables

Establishment costs would be about 254 000 euros for 20 collection points. The annual costs for the emptying and transportation are 327 600 euros and maintaining costs would then be 7 200 euros per year. The annual costs would then be 334 800 euros altogether.

Kerbside collection of the recoverables

As the paper and cardboard are the largest fraction and it would be emptied once per day, the number of containers needed would be 133. Other containers would be emptied more rarely. The final sum of the establishing of the system would be 150 450 euros. The pure emptying costs would be 606 879 euros and annual maintaining cost is 5 320 euros which makes annual costs to be 612 199 euros.

Transfer costs of the recoverables

If all the recoverables were used as material, the total annual costs of transfer of recoverables would be 222 021 euros. If all the combustible recoverables were used for the energy production and only metal and glass for material use, the price would be different. Transportation costs of combustible materials would be 185 280 euros annually. The metal and glass would be used as material with transfer price for metal 28 384 euros and for glass 56 768 euros.

Bio-waste collection

The number of the bio-waste containers would be reasonable to be the same than of containers for other recoverables (133) and they could be emptied four times per week. The total costs of purchasing bio-waste containers could be 9 031 euros. The total cost of collection and transportation of the bio-waste would be 104 220 euros and the treatment of one tonne of bio-waste in the small-scale composting plant makes 173 700 euros annually. Annual costs of the maintaining the system and collecting, transporting and treating the bio-waste are 279 250 euros. The profit from the selling of compost is 5 790 euros.

If the produced biomass will be treated anaerobically for the production of biogas, the cost for the treatment of one tonne of bio-waste in small-scale anaerobic digester would be 26 055 euros annually. The amount of biogas would be 451 620 KWh and the value

of produced electricity is 15 355 euros and the selling price of the produced compost makes 5 790 euros.

The selling price of the recoverables

The total selling price for all the collected recoverables for material use would be 731 962 euros. The selling price of metal would be 158 752 euro and of glass 46 416 euros in energy use option.

The price of the landfilling

If all the recoverables were collected separately, the amount of landfilled waste would decrease drastically. The only landfilled waste sectors would be wood, textile, garden waste, waste from treatment, leather, rubber, stones, bones and ceramics. The amount of landfilled waste would be 4 450 tonnes (33 712 m³) annually instead of prevailing 10 960 tonnes. Annual costs of the landfilling of the mixed waste would be 406 850 euros altogether.

As the service coverage in this Scenario is 80 %, 20% of MSW is not collected by this system. It should be collected as other mixed waste costing 145 080 and treat as landfilled waste which would cost 70 122 euros. Annual maintaining costs would be 5 870, which makes the annual costs 221 072 altogether (table 21).

Table 21. Conclusions of the Scenario 1.

Establishment costs of the 20 regional collection points for recoverables	254 000 euros
or	
Establishment costs of the 133 kerbside collection points for recoverables	150 450 euros
Establishment costs of bio-waste collection system	9 031 euros
Establishment costs of mixed waste collection system	Already existing
Annual costs of the 20 regional collection points	334 800 euros
or	
Annual costs of the 133 kerbside collection points for recoverables	612 199 euros
Annual costs of the bio-waste management system (aerobic)	279 250 euros
or	
Annual costs of the bio-waste management system (anaerobic)	131 605 euros
Annual costs of the mixed waste collection system	627 922 euros
Transfer costs of the recoverables in the material use option	222 021 euros
or	
Transfer costs of the combustible recoverables to the energy use locally	185 280 euros

and	
Transfer costs of the metal and glass to be used as material	85 152 euros
The selling price of the recoverables in the material use option	731 962 euros
The selling price of the compost (in biomass composting)	5 790 euros
or	
The selling price of the electricity and compost from anaerobic digestion	21 145 euros

Scenario 2 (partial recovery)

Scenario 2 is based on the partial collection of all the recoverables. The justification for this Scenario is, that it can be easily seen from the history of Finland (e.g. figure 15) that the recovering system cannot be established overnight. It would be good achievement to be able to collect half of the recoverables based on the same assumptions than in Scenario 1 (year 2017, 30 000 inhabitants, 80% service coverage and generated MSW amount 1104g/week/person) but all the inhabitants would recover half of the possible waste fractions. The weekly amount of recovered paper and cardboard would be 18,6 tonnes (464 m³), the amount of bio-waste 16,7 tonnes (56 m³), plastic 11,2 tonnes (318 m³), glass 9,3 tonnes (30,9 m³) and metals 4,7 tonnes (23,2 m³). The regional collection point for this Scenario would be the same than in figure 11. Almost all the costs and benefits would be half of those in Scenario 1.

The biggest difference between the Scenario 1 and 2 would be that if only the half of all the recoverables were collected separately, the amount of landfilled waste would decrease, but not so much than in Scenario 1. The landfilled waste sectors would be half of all the recoverable and also wood, textile, garden waste, waste from treatment, leather, rubber, stones, bones and ceramics. The amount of landfilled waste would be 7 705 tonnes (58 371 m³) annually compared to the 4 450 tonnes in Scenario 1 and 10 960 tonnes in the prevailing situation.

In the Scenario 2, the costs of landfilling would be higher than half of the costs in the Scenario one. In that case there is need for 1 870 mixed waste containers emptied once a week. The maintaining costs 18 700 euros and collection and transportation costs 462 300 are euros annually. The price for the landfilled MSW tonne makes 223 445 euros altogether. Hence the annual price for landfilled MSW would be 704 445 euros.

In addition, as the service coverage in this Scenario is also 80 %, 20% of MSW is not collected by this system. It should be collected as other mixed waste costing 145 080 and treat as landfilled waste which would cost 70 122 euros. Annual maintaining costs would be 5 870 which makes 221 072 altogether (table 22).

Table 22. Conclusions of the Scenario 2.

Establishment costs of the 10 regional collection points for recoverables	127 000 euros
or	
Establishment costs of the 67 kerbside collection points for recoverables	75 225 euros
Establishment costs of bio-waste collection system	4 515 euros
Establishment costs of mixed waste collection system	Already existing
Annual costs of the 10 regional collection points	167 400 euros
or	
Annual costs of the 67 kerbside collection points for recoverables	306 100 euros
Annual costs of the bio-waste management system (aerobic)	139 625 euros
or	
Annual costs of the bio-waste management system (anaerobic)	65 803 euros
Annual costs of the mixed waste collection system	925 517 euros
Transfer costs of the recoverables in the material use option	111 011 euros
or	
Transfer costs of the combustible recoverables to the energy use locally	92 640 euros
and	
Transfer costs of the metal and glass to be used as material	42 576 euros
The selling price of the recoverables in the material use option	365 981 euros
The selling price of the compost (in biomass composting)	2 895 euros
or	
The selling price of the electricity and compost from anaerobic digestion	10 573 euros

Scenario 3 (experiences in Finland)

The Scenario 3 is based on figures in the report of the Ministry of Environment (2010b) and the population of Kostamuksha. In that report the data from various waste management companies are used when the new collection point system is planned so that data may be useful for Kostomuksha as well. The annual amounts of collected recoverables in that report were 5,6 kg/person/year for cardboard, 0,35 kg/person/year for plastic, 0,23 kg/person/year for metal and 1,8 kg/person/year for glass. The annual amounts of these waste sectors for 30 000 inhabitants would then be 168 tonnes of cardboard and paper, 10,5 tonnes of plastic, 6,9 tonnes of metal and 54 tonnes of glass.

The weekly amounts would be about 3,2 tonnes of cardboard, 0,2 tonnes of plastic, 0,13 tonnes of metal and one tonne of glass. In volumes they would be 80 m³ of cardboard, 5,7 m³ of plastic, 0,65 m³ of metal and 3,3 m³ of glass.

Regional collection points of the recoverables

As the volumes are remarkably lower than in Scenarios 1 and 2, the number of regional collection points and emptying times needed are much lower than in the earlier Scenarios. The establishment and annual costs of the two regional collection points would be one tenth of the costs in Scenario 1 but the emptying costs would be different, 14 600 euros. The annual costs of maintaining would be 720 euros. The annual costs of two collection points would be 15 320 euros.

Kerbside collection points of the recoverables

The establishment of the kerbside collection system could be based on 10 kerbside collection points and establishment costs would be 11 312 euros. The emptying of the containers would cost 27 430 euros and maintaining costs would be 400 euros. Total annual costs of the kerbside collection would then be 27 830 euros.

Transfer costs of recoverables

As the amounts of the recoverable are low, there won't be many annual transfer trips. The annual transportation costs to Segezha and back would then be about and from there to Pertrozavodsk and back 14 032 euros. These costs most probably would be lower since it is not reasonable to drive without full loads but combine the recoverables from other cities to the same vehicle. If all the combustible material will be incinerated, the transfer costs of glass and metal to material use is 6 239 euros and the transportation costs of combustible material to be incinerated locally 10 710 euros annually.

The selling price of the recoverables

The annual selling price of the recoverables would be 25 655,7 euros altogether in material use option. The annual selling price of the recoverables would in energy use option would be 2263,2 for metal and 2 592 euros for glass.

Bio-waste collection

The amount of collected bio-waste in Scenario 3 is not based on any Finnish experiments but is set in scale with the amount of other collected recoverables this

Scenario being about one tenth of the bio-waste in Scenario 1 and the number of collection points about 13. All the costs and benefits of collecting, managing and treating of the bio-waste would be about one tenth of the Scenario 1.

The price of the landfilling

The amount of mixed waste is high in this Scenario being 11 678 tonnes (88 469m³). The transportation costs would be 700 674 euros and the treating of the mixed waste 338 659 euros. The maintaining costs would be 28 360 euros. The total annual costs of the mixed waste is then 1 067 693 euros (table 23).

Table 23. Conclusions of the Scenario 3.

Establishment costs of the 2 regional collection points for recoverables	25 400 euros
or	
Establishment costs of the 10 kerbside collection points for recoverables	11 312 euros
Establishment costs of bio-waste collection system	903 euros
Establishment costs of mixed waste collection system	Already existing
Annual costs of the 2 regional collection points	15 320 euros
or	
Annual costs of the 10 kerbside collection points for recoverables	27 830 euros
Annual costs of the bio-waste management system (aerobic)	27 925 euros
or	
Annual costs of the bio-waste management system (anaerobic)	13 161 euros
Annual costs of the mixed waste collection system	1 067 693 euros
Transfer costs of the recoverables in the material use option	14 032 euros
or	
Transfer costs of the combustible recoverables to the energy use locally	10 710 euros
and	
Transfer costs of the metal and glass to be used as material	6 239 euros
The selling price of the recoverables in the material use option	25 656 euros
The selling price of the compost (in biomass composting)	579 euros
or	
The selling price of the electricity and compost from anaerobic digestion	2 115 euros

Scenario 4 (experiences in Arkhangelsk)

Scenario 4 is based on the experiences of the pilot source separation and collection experiments carried out in Arkhangelsk in 2005 (Koivisto 2006). In the experiment, the collection points for paper and cardboard and for plastic and glass bottles and metal

cans were established for the trial time of two months. The collection area was the area of Varavino with about 11 000 inhabitants. There were 18 containers for paper and cardboard and 13 containers for bottles and cans near the existing waste collection points. The containers for paper and cardboard were emptied every other day and the containers for bottles and cans every tenth day. (Koivisto 2006)

The collected amount of paper and cardboard in this experiment was 0,0197 m³ per inhabitant in two months which makes 0,1182 m³ annually. If the whole Kostomuksha (30 000 inhabitants) would collect the same amount of paper and cardboard, it would make 3 546 m³ (142 tonnes) annually and 68 m³ (2,72 tonnes) weekly. The amount of paper in that fraction was only 40 %, which is 27,3 m³ weekly. The collected amount of bottles and cans were 0,53 kg/inhabitant in two month. The volume of collected plastic bottles were 28 m³, of glass bottles 11,9 m³ and of aluminum cans 7,6 m³ in two months which makes 168 m³ of plastic, 71, 4 m³ of glass and 45, 6 m³ metal in one year for 11 000 inhabitants. When calculated for 30 000 inhabitants in Kostomuskha, the annual amounts would be 458 m³ (16 tonnes) plastic, 195 m³ (58,5 tonnes) glass and 124 m³ (24,8 tonnes) metal which are 8,81 m³ (0,31 tonnes) plastic, 3,75 m³ (1,13 tonnes) glass and 2,38 m³ (0,476 tonnes) metal per week. The amounts of recoverables are then quite similar than in Scenario 3 but much lower than in two first Scenarios.

Regional collection points of the recoverables

When thinking of regional collection points, the volumes of recoverables are not big in the Scenario 4. Two regional collection points would be enough but the emptying times would be different than in the Scenario 3. The emptying and transporting costs would be 16 380 euros and the annual costs of maintaining would be 720 euros. The annual costs of two regional collection points would be 17 100 euros.

Kerbside collection points of the recoverables

The establishment of the kerbside collection system could be based on 10 kerbside collection points. The establishment costs of the containers would be 11 312 euros. The emptying of the containers would be 32 110 euros. The maintaining costs would be 400 euros. Total annual costs of the kerbside collection would then be 32 510 euros.

Transfer costs of recoverables

The amounts of the recoverables and transfers are low and almost similar than in Scenario 3. The annual transportation costs to Segezha and back would then be about 13 175 euros. By combining the transportations, these costs most probably would be lower. If all the combustible material will be incinerated, the transfer costs of glass and metal to material use is 6 239 euros and the transportation costs of combustible material to be incinerated locally 9 480 euros annually.

The selling price of the recoverables

The annual selling price of the recoverables for material use would be 23 440 euros altogether. The annual selling price of the recoverables in energy use option would be 8 134 euros for metal and 2 808 euros for glass.

Bio-waste collection

As there was no collection of bio-waste in Arkhangelsk there are no estimates for bio-waste collection. The collectable amount on bio-waste is set in scale with the amount of other collected recoverable in this Scenario as well, being same than in Scenario 3.

The price of the landfilling

The amount of mixed waste is high in this Scenario being 11 676 tonnes (88 455 m³). The transportation costs would be 700 560 euros and the treating of the mixed waste 338 604 euros. The maintaining costs are 28 350 euros. The total annual costs of the mixed waste in Scenario 4 is then 1 067 514 euros (table 24).

Table 24. Conclusions of the Scenario 4.

Establishment costs of the 2 regional collection points for recoverables	25 400 euros
or	
Establishment costs of the 10 kerbside collection points for recoverables	11 312 euros
Establishment costs of bio-waste collection system	903 euros
Establishment costs of mixed waste collection system	Already existing
Annual costs of the 2 regional collection points	17 100 euros
or	
Annual costs of the kerbside collection points for recoverables	32 510 euros
Annual costs of the bio-waste management system (aerobic)	27 925 euros
or	
Annual costs of the bio-waste management system (anaerobic)	13 161 euros
Annual costs of the mixed waste collection system	1 067 514 euros

Transfer costs of the recoverables in the material use option	13 175 euros
or	
Transfer costs of the combustible recoverables to the energy use locally	9 480 euros
and	
Transfer costs of the metal and glass to be used as material	6 224 euros
The selling price of the recoverables in the material use option	23 440 euros
The selling price of the compost (in biomass composting)	579 euros
or	
The selling price of the electricity and compost from anaerobic digestion	2 115 euros

Scenario 5 (no recovery at all)

In Scenario 5, the situation would be the same than in 2012 without any recovery. As there would be no establishment costs, all the waste management costs would be from the emptying of the containers, transportation and treating of waste. In addition there would be the maintenance costs of containers. The annual costs of landfilling 12 091 tonnes of wastes would then be 1 105 459 euros (table 25).

Table 25. Conclusions of the Scenario 5.

Establishment costs of mixed waste collection system	Already existing
Annual costs of the mixed waste collection system	1 105 459 euros

Summary of the Scenarios

Establishment costs of the collection systems

The establishment costs of collection system for recoverables naturally differ depending on the amount of recoverable waste, number of collection points and containers needed for the system varying from zero to 20 in different Scenarios. The establishment of the regional collection point seems to be more expensive option (on average double the price) compared to the kerbside collection point. The reason for that may be the fact that it needs bigger and more expensive containers with good foundation and better planning of the location of the space-demanding point. The kerbside collection point can be easily established by using smaller containers next to existing mixed waste containers. The price for mixed waste containers was not estimated since they already exist.

The annual costs of regional collection points are lower than in kerbside collection points, since the emptying times are lower. In Scenarios 3 and 4, the number of regional points was only two which is not ideal when thinking of the rational use (location, distance from households) of the collection points. Therefore the location of collection points needs to be considered carefully. There is possibility to establish several regional collection points and empty them more rarely, only when needed. This situation is not analyzed in any Scenarios. The bio-waste collection is always kerbside collection due to the moist content of the bio-waste. Bio-waste containers are usually emptied four times per week.

The annual costs of different waste fractions vary markedly depending on the type and the amount of waste. When considering the treatment of the bio-waste, the price of the anaerobic digestion is remarkably lower than the composting of the same amount of the bio-waste, even without the selling of the produced biogas. Annual costs of transfer to the transfer station or utilization facilities does not seem to cause huge costs, since it is done with larger vehicles, it lowers the landfilling costs and also the local transportation to the landfill. In annual costs it can be clearly seen, that the local transportation costs are strongly affecting the price of waste management. It is really hard to estimate the real transportation costs of recoverables from collection points to e.g. local storage, since there are no any estimates but the price of the collection of mixed waste for that use. The transfer costs are more easily calculated but they are based on Finnish experiences, not on Russian ones.

Total annual costs of MSW system

The estimated annual costs of waste management systems with cheapest management options (regional collection system for dry recoverables, kerbside bio-waste collection and treatment by using anaerobic digestion and material use of other recoverables) (table 26). Incomes consist of selling the recoverables and compost and biogas from the digester.

Table 26. Annual costs of existing system and in different Scenarios (kerbside bio-waste collection and anaerobic treatment; regional collection and material use for other recoverables)

	Establishment costs of collection systems for all recoverables (euros)	Annual costs without incomes from all recoverables (euros)	Annual costs with incomes from all recoverables (euros)
Existing system		1 002 050	
Scenario 1	263 031	1 316 348	563 241
Scenario 2	131 515	1 269 731	893 177
Scenario 3	26 303	1 110 206	1 083 971
Scenario 4	26 303	1 110 950	1 086 931
Scenario 5		1 105 459	

When comparing the existing system with the Scenario 5 (no recovering at all in both systems) it can be seen that the waste management will be more expensive after five years due to the increased amount of MSW generated.

Selling price of the recoverables

The selling price of the recoverables is essential when considering the benefit of the establishment of the collection system for the recoverables. The weaknesses in the assumption of the utilization of the recoverables collected from Kostomuksha is, that there is no information if the factories in Kostomuksha, Segezha or Petrozavodsk is able or willing to receive the recovered material. It may then be that there won't be any incomes from the recovered material. If the waste materials in Kostomuksha had the same price than the waste material in Europe, the selling of it would give incomes and lower the waste management price in Kostomuksha. The amount of incomes clearly depends on the amount of sold material. The treating of biomass can also produce compost and biogas but the incomes are much lower than from the sales of other recoverables.

Establishment costs of small-scale treatment facilities.

In case of the collection of the biomass, there is need to establish a small-scale biomass composting plant or anaerobic digester to Kostomuksha so that the collected biomass can be utilized. If the size of the plant were of 6 000 tonnes, the establishment costs of composting plant would be about two million euros and the establishment of anaerobic digester 670 000 euros (table 27). In addition, the annual treating costs of the bio-waste is much lower in anaerobic digester than in composting plant, and the selling of the biogas would produce incomes. It needs to be noticed that amounts of collected bio-

waste must be large enough to establish bio-waste treatment plant. If there is need to establish a new landfill to Kostomuksha, the estimate of the establishing of the landfill of suitable size would be about 1,3 million euros.

Table 27. Establishment costs of small-scale treatment facilities (Luostarinen 2008, Illikainen 2007 and Vänskä 2007 in Myllymaa et al. 2008b)

Establishment costs of the composting plant for 6 000 tonnes/a + total annual costs of treating the bio-waste (100 e/tonne)	2 000 000 euros
or	
Estab. costs of anaerobic digester for 6 000 tonnes/a+microturbine (90 kW) + total annual costs of treating the bio-waste (15 e/tonne)	670 000 euros
Estab.costs of new landfill for 11 000 tonnes/year (5,2 Milj.e/45 000 t/year) + total annual costs of treating the mixed waste (30 euro/tonne)	1 300 000 euros

7.4 Implementation part: Conclusions from the Scenarios

These calculations are based on reliable data about waste amounts, population dynamics and existing waste management situation in Kostomuksha. The formulas and statistics are based on literature and recent research results and they are provided from many well-known institutions and organizations. The exact texture of the MSW is not known, and neither is the service coverage. The amount of MSW after 30 years may not be so accurate (table 16), since the amount of waste is almost double compared to the present situation. It is justified that the amount of MSW will increase (changes in consumption, better living standards, new packaging materials) but it would be realistic to assume, that the amount of produced waste would stabilize after two or three decades as in many industrial countries.

All the Scenarios are based on the guidelines found from the literatures and/or the experiments in Finland or Russian Federation. Hence, there was a justification of using them. Scenario 1 was based on the maximum yield where all the citizens would separate and take all their recoverables to the collection points right away when the points would have been established. This may not be very reasonable Scenario to start with because not even in Finland all the citizens are separating their wastes. Scenario 2 is based on the fact that half of the recoverables are recovered. This may well be the situation after few years or decades after the establishment of the collection system. Scenarios 3 and 4 are quite similar and are based on the experiences in Finland and Russian Federation. As they support each other, they would be very well argued with good possibilities to succeed and something to start with.

When considering the establishment and annual costs, the most reasonable combination for the establishment of the MSW collection system is to use regional collection points for all the dry recoverables and kerbside collection for bio-waste and mixed waste, to establish and use anaerobic bio-waste treatment plant and to transfer other recoverables than bio-waste to be recovered as material, especially if there will be any incomes from the selling of waste material to the industry. However, the price of the local energy use of combustible material seems to be unreasonable high since there was no proper examples how to calculate it. Therefore it needs to be noticed, that this planning of MSWM system for Kostomuksha is not ideally suited for local circumstances and official planning would demand more accurate information about the area. Also the participation of the local stakeholders and public would be essential.

8. Discussion and conclusions

The aim of this work was to study sustainable municipal solid waste management strategies for sparsely populated Northern area and to develop a municipal solid waste management (MSWM) strategy for the city of Kostomuksha in the Republic of Karelia, Russian Federation. For that, there was a need to study the legislation and MSW systems in several countries, estimate the costs of establishment of well-functioning MSW systems and research what is the prevailing situation in the Northern countries and areas at the moment. After presenting the basic idea of the strategic municipal waste management planning the suggestions for the MSWM system for the city of Kostomuksha was presented.

EU legislation requires Member countries to make waste management plans which follow relevant EU directives. To achieve a reasonable and well-functioning MSW management system, the principles of sustainable development, integrated solid waste management and the waste management hierarchy must be included and practice at all the possible levels (e.g. national, regional and municipal levels). Especially in the EU countries the high level of recovering the waste and small amount of disposed waste is mainly due to the strict legislation with waste hierarchy which states that the prevention of the waste is the most important task, after which the generated waste material should be re-used, or recovered as material or as energy. Landfilling is the last option is to dispose the waste. As the amount of waste and MSW is still increasing in many countries and the sources of virgin raw materials are limited, the obeying of the waste hierarchy will come even more important in the future. Strategic planning is necessary so that MSWM services meet the demand, are suitable to needs, and are cost-effective.

Whereas the amount of wastes and MSW has increased quite fast with the urbanization and growth in gross domestic product, the progress of the proper MSW management system has been quite rapid as well. As the MSWM in the old EU Member States is considered to be at the good level, the new Members can use the experiences from these well-functioning systems when establishing their own. By establishing separation and collection systems may already help to start recovery if a proper waste management system is non-existent. Planning is a continuing process and the service must be

evaluated and revised constantly to ensure sustainable improvements to future service coverage and standards.

The MSWM planning process itself consists of six phases: general considerations, status part, planning part, consultation process, implementation and plan revision. When starting to plan the MSWM system it is essential to consider the waste management principles, e.g. waste hierarchy. In the next stage, the present situation is studied very carefully before the actual planning and implementation is started. An important part of the planning process is the consultation of the experts. Naturally the organizing of the well-functioning MSW management system is causing costs. In many countries it is expected that the incomes of the system (e.g. waste taxes, fee, profits from the sale of the products) covers the costs of the whole system.

The problems of well-functioning MSWM system vary in different countries and even in the different parts within one country. The first factor affecting is the location and area of the waste management system. It is always easier to establish MSWM systems in densely populated areas with short transportation distances and many utilization facilities (both as material and energy). In large cities it also may be reasonable to establish waste incineration plants since the transportation distances are not too long and the waste amounts are large enough to ensure the steady generation of the waste fuel. The history and the attitude of the people towards the environmental issues affect as well, as in some areas the environmental investments are seen only as extra costs.

To achieve a sustainable MSWM system in sparsely populated Northern areas, characterized by low waste volumes and long transportation distances, is challenging. The city of Oulu, the largest city in Northern Finland, has a well-organized MSWM system, whereas Lapland, the most sparsely populated area of Finland, still faces many challenges in its MSWM systems. In addition, as the generated waste amounts are low in Lapland, it needs to be considered carefully if it is reasonable to transfer the recoverables to be utilized as energy or as material. However, the waste hierarchy sets the rules for the waste management also in Lapland and the proper way to handle waste is increasing the well-being and protection of the environment in Lapland.

There was no information about well-functioning Russian MSWM systems. Recovery and recycling rates are low, and there is no MSW recovery infrastructure in the

Republic of Karelia. In addition, there are environmental problems with existing landfills and illegal dumping throughout the Russian Federation. However, as the awareness of environmental issues is increasing among Russian people, there is growing interest to establish recovery system for MSW. Because the MSW amounts are increasing also in the Russian Federation, this recovery system would be essential.

The MSWM plan for the city of Kostomuksha is mainly theoretical. As a background information, it is known that there is interest towards the more sustainable waste management system in the city which is essential when starting to plan the establishment of such system. As a status phase, it is important to estimate the waste amounts now and in the future, before considering the collection network of recoverables. In the planning phase, it is good to make some scenarios about the collection networks for the planning area. It is not always environmentally wise to collect and transport small amounts of recoverables over long distances, as it may be in the case of Kostomuksha. Therefore, it is important in the implementation phase to consider larger regions as a whole, establish transfer stations and utilize the waste in a centralized manner. As a case in point, Lapland has only three waste centers but several transfer stations and many smaller composting plants for bio-waste and waste water sludge.

Using the information on prevalent MSW amounts in Kostomuksha, present and future amounts of waste fractions were estimated and scenarios on the recovery and utilization of these waste fractions were presented. It was concluded that the best option would be to separately collect bio-waste at kerbside and treat in an anaerobic digester. Other major recoverable fractions (paper and cardboard, plastic, metal and glass) would be reasonable to collect in centralized collection points and transfer to utilization facilities through transfer stations. In order to implement this plan, it is essential to have recipient facilities in a reasonable distance and an infrastructure of transfer stations built in the Republic of Karelia. This will require regional level legislative control and political agreement in the Republic of Karelia. On the municipal level, also information and education campaigns will need to be planned in order for the public to get involved and participate in separate waste collection.

9. References

- Akkukierrätys (2008) – Tuottajayhteisö Akkukierrätys Pb Oy – Tuottajayhteisö. Available at: <http://www.akkukierrätys.fi/Yritys-%20ja%20yhteystiedot.htm>
- ArcticStat (2012)10.1. Gross regional product 1995, 2000-2005. Russian Federation. Table 2008-08-25-13. Available at: http://www.arcticstat.org/Table.aspx/Region/Russian_Federation/Indicator/%5BRegion_al_Accounts%5DGross_Product/2008-08-25-13/10911
- Avfall Sverige (2011) Swedish waste management. Available at: http://www.avfallsverige.se/fileadmin/uploads/Rapporter/Utveckling/Rapporter_2011/SAH_eng111219.pdf
- Chamilos, I. (2011) Resource efficiency in an urban context: Defining the framework of eco-municipalities. University of Oulu. Faculty of technology. Dept. of Process and Environmental Engineering. 80 p. 2 appendices.
- EEA (2007) The road from landfilling to recycling: common destination, different routes. European Environment Agency. Available at: http://www.eea.europa.eu/publications/brochure_2007_4
- Elinkeinoelämän keskusliitto (2011) Uusi jätelaki selkeyttää jätteen määritelmän. [Internet document] 15.03.2011 Created. Available at: http://www.ek.fi/ek/fi/ajankohtaista/uusi_jatelaki_selkeyttaa_jatteen_maaritelman-5823
- Elker Oy (2010a) Producer Responsibility. Published 2010. [Internet document] Available at: http://www.elker.fi/en/tuottajayhteisot_en/tuottajavastuu_en
- Elker Oy (2010b) SELT Association. Published 2010. [Internet document] Available at: http://www.elker.fi/en/tuottajayhteisot_en/selt_en
- Elker Oy (2010c) ICT Producer Co-operative. Published 2010. [Internet document] Available at: http://www.elker.fi/en/tuottajayhteisot_en/ict-tuottajaosuuskunta_en
- Elker Oy (2010d) FLIP Association. Published 2010. [Internet document] Available at: http://www.elker.fi/en/tuottajayhteisot_en/flip_en
- Elker Oy (2010e) Recycling. Published 2010. [Internet document] Available at: http://www.elker.fi/en/FAQ_en/Recycling
- The Environmental Register of Packaging PYR Ltd (2011a) Concepts used in recovery [Internet document] Publication unknown. Available at: <http://www.pyr.fi/eng/statistics/concepts.html>
- The Environmental Register of Packaging PYR Ltd (2011c) What is packaging recovery? [Internet document] Publication unknown. Available at: <http://www.pyr.fi/eng/recovery.html>
- The Environmental Register of Packaging PYR Ltd (2011e) Carton liquid packaging [Internet document] Publication unknown. Available at: <http://www.pyr.fi/eng/producer-organisations/carton-liquid-packaging.html>

Euregio Karelia (2010) Karjalan kartta. [Internet document] Available at:
<http://www.euregiokarelia.com/wp-content/uploads/2010/06/kartta.jpg>

Europa (2009) Directive on waste. Summary of EU legislation. Available at:
http://europa.eu/legislation_summaries/environment/waste_management/ev0010_en.htm#KEY

Europa (2011) Environment in the EU27 Recycling accounted for a quarter of total municipal waste treated in 2009. Eurstat newsrelease. [Internet document] Available at:
<http://europa.eu/rapid/pressReleasesAction.do?reference=STAT/11/37&format=HTML>

European Commission (2003) Preparing a Waste Management Plan. A methodological guidance note. European Commission Environment DG. European Topic Centre on Waste and Material Flows. Available at:
http://ec.europa.eu/environment/waste/plans/pdf/wasteguide_final.pdf

European Commission (2008) Convergence with EU Waste Policies. Short Guide for ENP Partners and Russia. Policy Guide: Waste Policy. Available at:
http://ec.europa.eu/environment/enlarg/pdf/pubs/waste_en.pdf

European Commission (2011) Waste. [Internet document] 8.7.2011 (Updated). Available at: <http://ec.europa.eu/environment/waste/index.htm>

European Commission (2012a) Directive 2008/98/EC on waste (Waste Framework Directive). [Internet document] Available at:
<http://ec.europa.eu/environment/waste/framework/index.htm>

European Commission (2012b) Waste Framework Directive. Revision of the Waste Framework Directive. [Internet document] Available at:
<http://ec.europa.eu/environment/waste/framework/revision.htm>

European Commission (2012c) Use of economic instruments and waste management performances. Final raport, European Commission. Available at: http://ec.europa.eu/environment/waste/pdf/final_report_10042012.pdf

The European Recycling Platform (2011) About ERP Finland. [Internet document] Publication unkown. Available at: <http://www.erp-recycling.fi/index.php?content=12>

Europen (2011) Packaging and Packaging Waste Statistics in Europe: 1998-2008 An analysis of official EU data by EUROOPEN. The European Organization for Packaging and the Environment. Available at:
<http://www.europen.be/europen/files/File/Key%20Topics/Packaging%20&%20Packaging%20Waste%20Statistics%20Final%201998-2008.pdf>

Eurostat (2012) Recycling. European commission. Eurostat. Available at:
<http://epp.eurostat.ec.europa.eu/portal/page/portal/waste/data/wastemanagement/recycling>

EVD (2009) Market survey Russia - Waste and Waste Water. Ministry of economic affairs. Available at:
<http://stpetersburg.nlconsulate.org/binaries/content/assets/postenweb/r/rusland/netherlands-consulate-general-in-st->

petersburg/import/products_and_services/economy_trade/waste--waste-water/waste--waste-water/hippogallery%3Aasset

Finnish environment institute (2010a) Wastes and waste management. [Internet document] 6.8.2010 (Updated). Available at:
<http://www.ymparisto.fi/default.asp?node=6044&lan=en>

Finnish environment institute (2011a) Wastes. [Internet document] 2.12.2010 (Updated). Available at: <http://www.ymparisto.fi/default.asp?contentid=37856&lan=en>

Finnish environment institute (2011b) Waste management for businesses. [Internet document] 6.10.2011 (Updated). Available at:
<http://www.ymparisto.fi/default.asp?contentid=176215&lan=en>

Finnish environment institute (2011c) Producer responsibility in waste management. [Internet document] 6.8.2011 (Updated). Available at:
<http://www.ymparisto.fi/default.asp?contentid=188660&lan=en>

Finnish environment institute (2011d) Municipal wastes. [Internet document] 1/30/2008 (Updated) Available at: <http://www.ymparisto.fi/default.asp?node=18451&lan=en>

Finnish environment institute (2011e). Collection and transport of waste within Finland. [Internet document] 12/3/2009 (Updated) Available at:
<http://www.ymparisto.fi/default.asp?contentid=216783&lan=EN>

Finnish environment institute (2011f). Waste taxes and charges. [Internet document] 5/21/2008 (Updated) <http://www.ymparisto.fi/default.asp?contentid=280586&lan=EN>

HE 199/2010 vp Hallituksen esitys Eduskunnalle jätelaiksi ja eräiksi siihen liittyviksi laeiksi. (2010) Available at:
<http://www.ymparisto.fi/download.asp?contentid=121743&lan=fi>

Honkanen, H., Värri, H., Horttanainen, M., Luoranen, M., Soukka, R., & Alve H. (2008) Jätteiden ja sivutuotteiden hyötykäytön yhteistyön haasteet ja mahdollisuudet Kaakkois-Suomen ja Pietarin sekä Leningradin alueella, Material Exchange –hankkeen loppuraportti. Lappeenrannan teknillinen korkeakoulu Energiatekniikan osasto Lämpö- ja ympäristötekniikan laitos. Available at:
http://www.lut.fi/fi/technology/lutenergy/environment/research/projects/matex/publications/Documents/ME_raportti_www.pdf

Hänninen, K. (2009) Jätteiden käsittely ja kierrätys Suomessa. Jyväskylän yliopiston bio- ja ympäristötieteiden laitoksen tiedonantoja 87. University of Jyväskylä. Finland.

Illikainen, M. 2007a. Suullinen tiedoksianto 29.5.2007. Johtaja. Oulun Jätehuolto. In Myllymaa et al. 2008b.

Illikainen, M (2012) Personal notice. Johtaja. Jätehuollon kevätpäivä 26.4. Oulu.

Isoaho, S. 2008. Tampereen teknillinen yliopisto. Kirjallinen tiedonanto 3.3.2008. In Myllymaa et al. 2008b

Jätelaitosyhdistys (2011a) Jätteenpolton kehitysvaiheita. [Internet document] Publication unknown. Available at: <http://www.jly.fi/energia11.php?treeviewid=tree3&nodeid=11>

Jätelaitosyhdistys (2011b) Suomen yhdyskuntajätehuolto. [Internet document] Publication unknown. Available at: <http://www.jly.fi/jateh0.php?treeviewid=tree2&nodeid=0>

Jätelaitosyhdistys (2011c) Keräys. [Internet document] Publication unknown. Available at: <http://www.jly.fi/jateh1.php?treeviewid=tree2&nodeid=1>

Jätelaitosyhdistys (2011d) Kuljetukset. [Internet document] Publication unknown. Available at: <http://www.jly.fi/jateh2.php?treeviewid=tree2&nodeid=2>

Jätelaitosyhdistys (2011e) Jätteenkäsittely. [Internet document] Publication unknown. Available at: <http://www.jly.fi/jateh3.php?treeviewid=tree2&nodeid=3>

Jätelaitosyhdistys (2011f) Hyödyntäminen. [Internet document] Publication unknown. Available at: <http://www.jly.fi/jateh4.php?treeviewid=tree2&nodeid=4>

Jätelaitosyhdistys (2012a) Jäte energiaksi. [Internet document] Publication unknown. Available at: <http://www.jly.fi/energia1.php?treeviewid=tree3&nodeid=1> (1.2.1012)

Jätelaitosyhdistys (2012b) Tilastoja ja tunnuslukuja. [Internet document] Publication unknown. Available at: <http://www.jly.fi/jateh6.php?treeviewid=tree2&nodeid=6> (1.2.1012)

Kaplas, M (2009) Kotitalouksien, julkisen toiminnan ja yksityisten palvelujen jätemäärien erillisarvio. Henkilökohtainen tiedonanto. In Ympäristöministeriö (2010a) Jätehuollon taloudellinen merkitys ja kustannukset. Ympäristöministeriön raportteja 12 | 2010.

Koivisto, J. (2006) Syntypaikkalajittelukokeilu Arkangelin kaupungissa. Loppuraportti. HFT Network Oy.

Kuluttajavirasto 2010. Jätehuoltopalveluissa huomattavia hintaeroja. Tiedote. [Internet document] Available at: <http://www.kuluttajavirasto.fi/fi-FI/ajankohtaista/tiedotteet/2010/tiedote/10/jatehuoltopalveluissa-huomattavia-hintaeroja>

Kuntaliitto 2006. Jätehuollon järjestäminen kunnan näkökulmasta. Omistajaohjauksessa huomioon otettavia asioita. Helsinki.

Kuusakoski recycling (2011a). Sähkö- ja elektroniikkaromut (SER) kierrätykseen. [Internet document] Publication unknown. http://www.kuusakoski.fi/Kuluttajille/Kuluttajille_Sahko-_ja_elektroniikkalaitteet

Kuusakoski recycling (2011b). Kuusakoski Oy. [Internet document] Publication unknown. Available at: http://www.kuusakoski.fi/Yritysinfo/Kuusakoski_Oy

Lahdelma, J. (2002). Biojätteen erilliskeräyksen ja sekajätteenkeräyksen kustannusvertailu. Lappeenrannan teknillinen korkeakoulu Energiatekniikan osasto Lämpö- ja ympäristötekniikan laitos.

Laine, M. 2007. Kirjallinen tiedoksianto 16.4.2007. Envor Group Oy. In Myllymaa et al. 2008b.

Laukala, T (2011). Uusiomassan laatuluokat, ominaisuudet ja käyttökohteet. Lappeenrannan teknillinen yliopisto. Kemiantelekniiikan laitos. Kandidaatintyö. Available at: <http://www.doria.fi/bitstream/handle/10024/67499/nbnfi-fe201103091321.pdf?sequence=3>

Lapin ELY (2011) Lapin alueellinen jätesuunnitelma vuoteen 2020. Lapin elinkeino-, liikenne- ja ympäristökeskus. Available at: http://www.ely-keskus.fi/fi/ELYkeskukset/LapinELY/Ymparistonsuojelu/Documents/Lapin_jatesuunnitelma_2011_12_19.pdf

Lassila-Tikanoja (2012) Jäteastia ja astiasuojat. [Internet document] Available at: <http://www.lassila-tikanoja.fi/fi/PalvelutJaTuotteet/palvelujatuotevalikoima/ymparistotuotteet/jateastiat/Sivut/jateastiat.aspx>

Loseva, E. (2007) Pietarin jätehuolto ja jätteiden käsittelyteknologian kehitys. Kosmos. Presentation in Material Exchange seminar. Available at: http://www.lut.fi/fi/technology/lutenergy/environment/research/projects/matex/events/Documents/Kosmos_Loseva.pdf

Luostarinen, J. Metener Oy. Kirjallinen tiedoksianto 3.3.2008. In Myllymaa et al. 2008b.

Melanen M, Kautto P, Saarikoski H, Ilomäki M, Yli-Kauppila H. (2002) Finnish waste policy—effects and effectiveness. *Resour Conserv Recycl.* 35:1–15.

Mepak-Kierrätys (2011a) Mepak-Kierrätys Oy in English. [Internet document] Last modified: 28.01.2011 Available at: <http://www.mepak.fi/english.htm>

Mepak-Kierrätys (2011b) Mepak-Kierrätys Oy. [Internet document] Last modified: 28.01.2011 Available at: <http://www.mepak.fi/mepak.htm>

Molok ltd (2009) Basic Container. [Internet document] Publication unknown. Available at: http://www.molok.com/eng/main.php?loc_id=8

Motiva Oy 2007. Interaction toimenpide-selvitys - kuorma-autokuljetusten energia-, ympäristö- ja kustannustehokkuuden parantaminen. Available at: <http://www.jly.fi/interaction-toimenpideselvitys.pdf?PHPSESSID=11bfa37f4caf7c9f9b83c6aba2fa956f>

Municipal solid waste (2012) Municipal Solid Waste magazine. In EVD (2009) [Internet document] Available at: <http://www.solidwaste.ru/english.html>

Myllymaa, T, Moliis, K., Tohka, A., Isoaho, S., Zevenhoven, M., Ollikainen, M., & Dahlbo, H. (2008a) Jätteiden kierrätyksen ja polton ympäristövaikutukset ja kustannukset – jätehuollon vaihtoehtojen tarkastelu alueellisesta näkökulmasta. *Suomen ympäristö* 39 / 2008
Available at: <http://www.ymparisto.fi/default.asp?contentid=298884&lan=fi>

Myllymaa, T, Moliis, K., Tohka, A., Rantanen, P., Ollikainen, M., & Dahlbo, H. (2008b) Jätteiden kierrätyksen ja polton ympäristövaikutukset ja kustannukset – Inventaarioraportti. Suomen ympäristö 28 / 2008.

Available at: <http://www.ymparisto.fi/download.asp?contentid=92262>

Mäkelä, K. 2002. Yksikköpäästötietokanta (VTT Liisa). [Internet document] Available at: http://lipasto.vtt.fi/yksikkopaastot/henkiloliikenne/tieliikenne/henkilo_tie.htm

Nummela, E. 2007. Jätelaitosyhdistys ry. Kirjallinen tiedoksianto 1.11.2007. In Myllymaa et al. 2008b.

North Re-Tyre Oy (2010) Tervetuloa North Re-Tyre Oy:N, pohjoisen rengaskierrätyksen kotisivuille. [Internet document] Available at: <http://www.northretyre.com/>

Nord Pool Spot (2012) Elspot prices. [Internet document] Available at: <http://www.nordpoolspot.com/>

NP-kierrätys (2011a) Kierrätysohjeet. [Internet document] Publication unknown. Available at: <http://www.np-kierratys.fi/kierratysohjeet.php>

NP-kierrätys (2011b) Pakkauksen kiertokulku.. [Internet document] Publication unknown. Available at: http://www.np-kierratys.fi/pakkauksen_kiertokulku.php

OECD (2011) Municipal Waste. OECD Regions at a Glance 2011. Environmental Sustainability in Regions and Metropolitan Areas. OECD iLibrary. Available at: http://www.oecd-ilibrary.org/sites/reg_glance-2011-en/05/04/index.html?jsessionid=1s2dvipa67ub0.delta?contentType=&itemId=/content/chapter/reg_glance-2011-35-en&containerItemId=/content/serial/19990057&accessItemIds=/content/book/reg_glance-2011-en&mimeTy

Official Karelia (2012) The Republic of Karelia State Government Bodies´Official Web Portal. [Internet document] Available at: http://www.gov.karelia.ru/gov/index_e.html

Oulun kaupunki (2006) Jätehuoltomääräykset. Hailuoto, Kempele, Kiiminki, Liminka, Lumijoki, Muhos, Oulu, Oulunsalo, Tynävä, Ylikiiminki. Annettu jätelain 17 §:n nojalla. Oulun seudun ympäristölautakunta 22.11.2006 § 259 Available at: <http://www.ouka.fi/documents/64417/b844c5db-7723-4437-b94a-143f639e8b26>

Oulun Jätehuolto (2012a). Internetsivut. [Internet document] Available at: <http://www.ouka.fi/jatehuolto/index.asp>

Oulun Jätehuolto (2012b). Vuosikertomus 2009.

Oulu Waste Management (2012). Recycling and reuse. Oulun jätehuolto. Available at: http://www.ouka.fi/jatehuolto/PDFT/Esitteet/yleisesite_englanniksi_netti.pdf

Palpa (2011a) Recycling systems [Internet document] Publication unknown. Available at: <http://www.palpa.fi/retail-trade/recycling-systems>

Palpa (2011b) Suomen Palautuspakkaus Oy. [Internet document] Publication unknown. Available at: <http://www.palpa.fi/retail-trade/recycling-systems>

Palpa (2011c) Keep the deposit-based beverage containers in circulation – for the good of the environment. [Internet document] Publication unknown. Available at: <http://www.palpa.fi/english>

Palpa (2011d). Pullojen kierto. [Internet document] Publication unknown. Available at: http://www.palpa.fi/juomateollisuus/ekopullojen_kierratysjarjestelma/pullojen-kierto

Paperinkeräys Oy (2011a) Nationwide environmental service provider, recovered paper wholesaler and producers association. [Internet document] Publication unknown. Available at: <http://www.paperinkerays.fi/home>

Paperinkeräys Oy (2011b) Asukkaille. [Internet document] Publication unknown. Available at: <http://www.paperinkerays.fi/asukkaille>

Potapova, G. (2012) E-mail. Chief specialist. City of Kostomuksha.

Puupakkausten Kierrätys (2011) Tervetuloa puupakkausten kierrätys PPK OY:n kotisivuille. [Internet document] Publication unknown. Available at: <http://www.puupakkauskierratys.fi/>

Ramboll (2008) Järjestetyn jätteenkuljetuksen vaihtoehtojen vertailu. Oulun Jätehuolto, Oulun seudun jätteenkuljetusyrittäjät. Available at: http://www.jly.fi/oulu_jatehuolto_loppuraportti.pdf

Raimovaara (2004) Biokaasun tuotanto- ja käyttömahdollisuudet Kanta-Hämeessä. Hämeen ammattikorkeakoulu. Available at: <http://midgard1.nebula.fi/attachment/ee246cbb04c1da363116122aebb56633/19264351e78bffb4327fe0f8f522694/Biokaasun+tuotanto-+ja+hy%C3%83%C2%B6tyk%C3%83%C2%A4ytt%C3%83%C2%B6mahdollisuudet>

Recser Oy (2008) Recser Oy - Producer organisation for portable batteries and accumulators. [Internet document] Available at: http://www.recser.fi/en/?Home_page

Rengaskierrätys Oy (2011) Welcome to the Finnish Tyre Recycling Ltd's www-site. [Internet document] Latest update: 26.05.2011 Available at: <http://www.rengaskierratys.com/en/index.php/etusivu/>

Rodionov, M. & Toshihiko, N. (2011) Design of an optimal waste utilization system: A case study in St. Petersburg, Russia. Sustainability 3: 1486-1509.

SERTY (2011a) SER-tuottajayhteisö ry. [Internet document] Publication unknown. Available at: <http://www.serty.fi/>

SERTY (2011b). Toiminta ja jäsenet. [Internet document] Publication unknown. Available at: <http://www.serty.fi/fi/toiminta-ja-jaesenet>

Sokka, L., Antikainen, R. & Kauppi, P. (2004) Flows of nitrogen and phosphorus in municipal waste: a substance flow analysis in Finland. Progress in Industrial Ecology, Vol. 1, Nos.1/2/3

Sokka, L., Antikainen, R. & Kauppi, P. (2007) Municipal solid waste production and composition in Finland—Changes in the period 1960–2002 and prospects until 2020. *Resources, Conservation and Recycling* 50: 475–488

Suomen autokierrätys (2011a) Welcome to the homepage of Finnish Car Recycling! Publication unknown. Available at:
<http://www.autokierratys.fi/en/index.php?go=48;48;0;;49>

Suomen autokierrätys (2011b) Suomen autokierrätys (2011) Welcome to the homepage of Finnish Car Recycling! [Internet document] Publication unknown. Available at:
<http://www.autokierratys.fi/en/index.php?go=49;49;0;;48>

Suomen keräyslasiyhdistys (2011a) Yhdistyksen esittely. [Internet document] Publication unknown. Available at:
<http://www.kerayslasiyhdistys.fi/default.aspx?intObjectID=44>

Suomen keräyslasiyhdistys (2011b) Miten kierrättää lasia. [Internet document] Publication unknown. Available at:
<http://www.kerayslasiyhdistys.fi/default.aspx?intObjectID=98>

Suomen keräyslasiyhdistys (2011c) Pantilliset järjestelmät. [Internet document] Publication unknown. Available at:
<http://www.kerayslasiyhdistys.fi/default.aspx?intObjectID=70>

Suomen keräyslasiyhdistys (2011d) FAQ [Internet document] Publication unknown. Available at: <http://www.kerayslasiyhdistys.fi/default.aspx?intObjectID=63>

Suomen keräyslasiyhdistys (2011e) Mitä lasille tapahtuu? [Internet document] Publication unknown. Available at:
<http://www.kerayslasiyhdistys.fi/default.aspx?intObjectID=99>

Suomen keräyslasiyhdistys (2011f) Toiminnan esittely. [Internet document] Publication unknown. Available at: <http://www.kerayslasiyhdistys.fi/default.aspx?intObjectID=67>

Suomen keräystuote Oy (2011) Suomen Keräystuote Oy on keräyspaperin tuottajayhteisö. [Internet document] Publication unknown. Available at:
<http://www.suomenkeraystuote.fi/fi/tuottajavastuu/tuottajayhteiso/>

Suomen kuitukierrätys Oy (2011) Kuitupakkaukset. [Internet document] Publication unknown. Available at: <http://www.kuitukierratys.fi/index.php?documentid=3>

Suomen kuitukierrätys Oy (2012) Pakkausten uuden jätelain mukaista vastaanottoa pilotoidaan Tampereella ja Kuopiossa. [Internet document] Available at: <http://www.kuitukierratys.fi/index.php?documentid=4>

Suomen kuluttajakuitu ry (2011a) Pakkauksen kiertokulku. [Internet document] Publication unknown. Available at:
<http://www.kuluttajakuitu.fi/index.php?documentid=2>

Suomen kuluttajakuitu ry (2011b) Kysymyksiä ja vastauksia. [Internet document] Publication unknown. Available at:
<http://www.kuluttajakuitu.fi/index.php?documentid=7>

Suomen Teollisuuskuitu (2011) Suomen Teollisuuskuitu Oy - in English. [Internet document] Publication unknown. Available at:
<http://www.teollisuuskuitu.fi/indexeng.htm>

Suomen uusiomuovi (2009c) Uusinta uusiota-esite.

Suomen uusiomuovi (2009d) Muovipakkausten kierrätys. [Internet document] Publication unknown. Available at:
http://www.suomenuusiomuovi.fi/fin/tietoa_muoveista/usein_kysyttya/

Suomen virallinen tilasto (SVT) (2010a) Jätetilasto [Internet document].
 Liitetaulukko 1. Yhdyskuntajätteet vuonna 2009, tonnia . Helsinki: Tilastokeskus
 Updated 23.11.2010 Available at: http://www.stat.fi/til/jate/2009/jate_2009_2010-11-23_tau_001_fi.html

Suomen virallinen tilasto (SVT) (2010b) Jätetilasto 2009. Yhdyskuntajätteen määrä laski. [Internet document]. Julkaistu 23.11.2010 Available at:
http://www.stat.fi/til/jate/2009/jate_2009_2010-11-23_fi.pdf

Suomen virallinen tilasto (SVT) (2011a) Jätetilasto [Internet document].
 Liitetaulukko 2. Jätteiden kertymät sektoreittain ja jätelajeittain vuonna 2009, 1 000 tonnia vuodessa. Helsinki: Tilastokeskus Updated 20.5.2011 [viitattu: 27.7.2011].
 Available at: http://www.stat.fi/til/jate/2009/jate_2009_2011-05-20_tau_002_fi.html

Suomen virallinen tilasto (SVT) (2011b) Jätetilasto 2009. Kaivokset mineraalijätteen suurtuottajia. [Internet document]. Julkaistu 20.5.2011 Available at:
http://www.stat.fi/til/jate/2009/jate_2009_2011-05-20_fi.pdf

Suomen virallinen tilasto (SVT) (2011c) Jätetilasto [Internet document]. Kaivokset mineraalijätteen suurtuottajia. ISSN=1798-3339. 2009. Helsinki: Tilastokeskus
 Available at: http://www.stat.fi/til/jate/2009/jate_2009_2011-05-20_tie_001_fi.html.

Suomen virallinen tilasto (SVT) (2011d) Jätetilasto 2010 [Internet document]. Yhä suurempi osa yhdyskuntajätteestä polttoon. 2009. Helsinki: Tilastokeskus Available at:
[http://www.stat.fi/til/jate/2010/jate_2010_2011-11-18_fi.pdf_\(31.1.2012\)](http://www.stat.fi/til/jate/2010/jate_2010_2011-11-18_fi.pdf_(31.1.2012))

Suomen virallinen tilasto (SVT) (2011e) Rakennuskanta 2010. [Internet document].
 Helsinki: Tilastokeskus Available at:
http://www.stat.fi/til/rakke/2010/rakke_2010_2011-05-26_kat_002_fi.html

Suomen ympäristökeskus (2012) Jätteiden synty toimialoittain. [Internet document].
 Available at: <http://www.ymparisto.fi/default.asp?contentid=171384&lan=fi>
 (31.1.2012)

Teknologioteollisuus ry (2012) Standardi-terästuotteiden sekä värimetallien hintoja. Talouden arviointi. pdf. [Internet document] Available at:
http://www.google.fi/url?sa=t&rct=j&q=&esrc=s&source=web&cd=4&ved=0CD4QFjAD&url=http%3A%2F%2Fwww.teknologioteollisuus.fi%2Ffile%2F2764%2FMetallien_hintoja.pdf.html&ei=eCWVT4rwBuqQ4gSUrOjQDw&usg=AFQjCNFder2MiTPEFrYp619Yknnma-UB3A&sig2=_COCxsowZ_q-nNmEDqCfkg

Tommila P (1984) editor. Suomen kaupunkilaitoksen historia 3. Itsenäisyyden aika. Helsinki, Finland: Suomen Kaupunkiliitto.

Turpeinen, O. (1995) Kunnallistekniikkaa Suomessa keskiajalta 1990-luvulle. Suomen kuntatekniikan yhdistys, Helsinki, Finland.

Turunen, T, Sallmén, M, Meski, S, Ritvanen, U. & Partanen, E. (2008) Oulun läänin alueellinen jätesuunnitelma. Jätehuollon kehittämisohjelma vuosille 2008 – 2018. Suomen ympäristö 6/2008. Available at:
<http://www.ymparisto.fi/download.asp?contentid=83715>

UNEP (2005) Integrated waste management scoreboard. A tool to measure performance in municipal solid waste management. United Nations Environment Programme. [Internet document] Available at:
http://www.unep.or.jp/ietc/Publications/spc/IWM_scoreboard-binder.pdf

Uusioaines Oy (2011b) Company operations. [Internet document] Publication unknown. Available at: <http://en.uusioainesoy.kotisivukone.com/12>

Vänskä, V. 2007. Kirjalliset tiedoksiannot 10.1. ja 18.9.2007. Joensuun Seudun Jätehuolto Oy. In Myllymaa et al. 2008b

Worldbank (2001) Strategic Planning Guide for Municipal Solid Waste Management. Available at: http://www.worldbank.org/urban/solid_wm/erm/start_up.pdf

Ympäristöministeriö (2008) Kohti kierrätysyhteiskuntaa. Valtakunnallinen jätesuunnitelma vuoteen 2016. Suomen ympäristö 32. Available at:
<http://www.ymparisto.fi/download.asp?contentid=91466&lan=fi>

Ympäristöministeriö (2010a) Jätehuollon taloudellinen merkitys ja kustannukset. Ympäristöministeriön raportteja 12 | 2010. Available at
<http://www.ymparisto.fi/download.asp?contentid=117613&lan=fi>

Ympäristöministeriö (2010b). Uuden jätelainsäädännön mukaisten keräysverkostovaatimusten kustannusvaikutukset pakkausten jätehuollossa. Raportti 1907-P11168. FCG Finnish Consulting Group Oy. Available at:
<http://www.ymparisto.fi/download.asp?contentid=121811&lan=fi>

YYL (2010) Jätehuollon hinta ei ole riippuvainen kuljetusjärjestelmästä. Tiedote. Ympäristöyritysten liitto. [Internet document] Available at:
<http://www.ymparistoyritykset.fi/tiedote?id=17405072>

Appendix. 1 Waste legislation in Finland

General waste legislation

- Waste Act (646/2011)
- Waste Decree (1797/2012)

End-of-waste

- Council Regulation (EU) No 333/2011 establishing criteria determining when certain types of scrap metal cease to be waste under Directive 2008/98/EC of the European Parliament and of the Council (333/2011)

Waste treatment and recovery

- Government Decree on waste incineration (362/2003)
- Government Decision on landfill sites (861/1997)

Legislation on specific waste types, products and activities

- Government Decree on end-of-life vehicles (581/2004)
- Government Decree on subsidies for the processing of end-of-life vehicles (582/2004)
- Government Decree controlling the use of certain hazardous substances in vehicles (572/2003)
- Government Decree on Waste Electrical and Electronic Equipment (852/2004)
- Government Decree controlling the use of certain hazardous substances in electrical and electronic equipment (853/2004)
- Government Decision on restricting the use of PCBs and PCTs (1071/1989)
- Government Decision on the prohibition of PCBs and equipment containing PCBs, and the processing of wastes containing PCBs (711/1998)
- Government Decision on ozone-depleting substances (262/1998)
- Council of State Decision on batteries and accumulators containing certain dangerous substances (105/1995)
- Government Decision on amalgam-containing wastewater and waste resulting from dental care (112/1997)
- Government Decision on the management of oily wastes (101/1997)
- Government Decision on the use of sewage sludge in agriculture (282/1994)
- Government Decision on the recovery and disposal of discarded tyres (1246/1995)
- Government Decision on construction waste (295/1997)
- Government Decision on the collection and recovery of waste paper (883/1998)
- Government Decision on packaging and packaging waste (962/1997)
- Ministry of the Environment Decision on derogations from limitations of heavy metal concentration levels in packaging (273/2000). In force 1.4.2000-10.2.2009.

Waste shipments

- Regulation (EC) No 1013/2006 of the European Parliament and of the Council on shipments of waste (EUR-Lex)
- Government Decision on the part of the National Waste Plan concerning transfrontier waste shipments (495/1998)

Other legislation

- Waste Oil Charge Act (894/1986)

Appendix 2. Producer responsibility organizations in Finland

Environmental Register of Packaging PYR Ltd

Pakkausalan Ympäristörekisteri PYR Oy (The Environmental Register of Packaging PYR Ltd) is a non-profit firm which co-operates with producer organizations in the packaging sector. It helps companies and the authorities to fill packaging recovery obligations since firms that place packed products on the market and have a sales volume of one million euro or more have a packaging recovery obligation/producer responsibility in Finland. If a firm has a contract with PYR, it transfers the recovery obligation to the producer organizations. (The environmental register of packaging 2011c)

Producer responsibility organizations for glass packaging

Suomen Keräyslasiyhdistys was established in 1998. It is producers' organization which promotes recycling and reusing of glass, and it aims to reduce production of waste glass by sharing information about recycling and reusing of glass and by collecting the utilization fee for glass packages. Organization makes statements and tries to find out new ways to recycle glass and gives municipalities reward for collected packing glass. The members of the organization are trade and importers, industry and companies using glass packaging (Suomen keräyslasiyhdistys 2011a).

Glass is collected using two different collection routes. Most of the glass is collected by using refund system which is organized by industry and trade and producer organization is decision-making body. Smaller part of glass ware is collected by the using municipal collection points. (Suomen keräyslasiyhdistys 2011e) Refundable glass packages can be returned to stores. Grocery shops are receiving beverage packagings they have sold and Alko accepts bottles for alcoholic beverages and soft drinks they have sold. Non-refundable packages can be returned to the nearest collection point. Recycled glass should be reasonable clean and sorted according to colour, if possible. (Suomen keräyslasiyhdistys 2011b). The number of collection points for refundable packages was estimated to be 8000 in 2002 (Suomen keräyslasiyhdistys 2011c).

To collection points can be returned all the clean waste glass: glass packaging (bottles and jars) and glassware. Glass material can be recycled basically forever since its quality won't suffer from reusing. Refillable bottles can be filled dozens of times (depending on the type of a bottle) until it is put out of circulation. After that, the glass can be used as a material for manufacturing new packages or glass wool. (Suomen keräyslasiyhdistys 2011d)

Refillable bottles are taken to breweries and alcoholic beverage plants for sorting, washing and refilling. Other glassware and disposable bottles with a deposit will be crashed and sorted according to their colour, after which they are used for the manufacturing of packing glass and glass wool. Part of glass from municipal collection points are crashed and sorted but some of them are landfilled. (Suomen keräyslasiyhdistys 2011e). The major suppliers of the packaging glass are Alko, beverage wholesalers and waste management companies. Deliverers of float glass (e.g. windows and windscreens) are glass sellers, cutters, downstream operators and construction companies. (Uusioaines Oy 2011b)

The law in Finland permits to use recycled cullet for producing new packing glass and glass wool. Recycled cullet has been used for the manufacturing of the glass wool since 1983. The proportion of waste glass in glass wool product is about 60-80% and the share of waste glass in new packing glass is about 20%. Recycled cullet can be used for other purposes as well, e.g. for the manufacturing of glass block and glass-concrete; in swimming pool filters; for land reclamation, sandblasting and road bed. In Finland the use for material in the road bed could be one good option since cullet has good frost resistance. In addition, there is need to discover new ways to utilize cullet because of the demand for higher utilization rate due to packing directive in future. (Suomen keräyslasiyhdistys 2011e).

Producer responsibility organizations for fibre packaging

The earlier producer organizations for fibre packaging, Suomen Kuluttajakuitu ry (consumer fibres), Suomen NP-kierrätys Oy (carton liquid packaging) and Suomen Aaltopahviihdistys ry (corrugated board), have closed down their operations as producer organisations. Together they have established Suomen Kuitukierrätys Oy but will go on with their activities in packaging recovery. (The Environmental Register of Packaging 2011e) Suomen Kuitukierrätys Oy producer is organization for fibre packages like paper, cardboard and corrugated cardboard packages. (Suomen kuitukierrätys Oy 2011)

Fibre packages are environmentally friendly since they can be re-used again. Usually these packages are packages used for customer products like cardboard boxes, paper bags, egg cases and disposable containers. Recyclable packages for liquid foodstuff belong to this group, e.g. milk and juice cartons, also aluminum coated. Corrugated cardboard is the most common material in the transport packings such as boxes and wrappings. Fibre packages are collected from properties and there are 1800-1900 collection points in densely populated area. Shops and industry produce corrugated cardboard and industrial fibres. Fibre packages are re-used as material for corrugated cardboard and cardboard but there is still need to develop applications that can replace the use of virgin wood or pulp. (Suomen kuitukierrätys Oy 2011)

All the carton liquid packagings are recyclable, even with aluminum coating and plastic parts (e.g. cap). Packages need to be washed and flattened and taken to the collection point. (NP-kierrätys 2011a) Empty carton liquid packagings are sorted, baled and transported to cardboard factory as raw material. Fibre is then separated from plastic and re-used as material for coreboard. (NP-kierrätys 2011b) Separated plastic is burned as energy and aluminum is recycled. (Suomen kuluttajakuitu ry 2011a). There is no need for deinking of the used packages. Recycled cardboard is used in the factory of Corenso United Ltd in Pori and Fiskeby cardboard factory in Sweden. (Suomen kuluttajakuitu ry 2011b).

Producer responsibility organizations for beverage containers

Suomen Palautuspakkaus Oy (PALPA) is owned by the retail trade and the breweries and it administers and develops deposit-based systems for beverage containers in Finland. The return percentage goal level is 90 %. The recycling system of beverage containers is very comprehensive in Finland since almost all soft drink, water, beer,

cider, long drink and sport drink bottles and cans have a deposit. Since 2008 recyclable plastic bottles (spring water, mead, iced tea and wine) have had a deposit. (Palpa 2011b)

PALPA administers the recycling of beverage containers. A very large proportion of the beverage containers is recycled or re-used because of the system of deposits paid on returned containers. (Palpa 2011c) The returning percentage of used bottles is very high, since 97% of the bottles are recycled. Glass bottles are used 33 times on average. Cast-off glass bottles are used for new glass ware or glass wool and labels are used as energy. (Palpa 2011d)

Nowadays the returning rate of beverage cans is about 90 %, which is top class worldwide. Returned aluminum cans are melted and used as material for new beverage cans and recyclable plastic bottles are not re-used as bottles but the plastic is recycled. (Palpa 2011a) Empty plastic bottles from the shops are transported to the recycling center, after which they are baled, crushed, washed, granulated for utilization as raw material e.g. for new bottles. (Palpa 2011d)

Producer responsibility organizations for plastics

Suomen Uusiomuovi Oy (The Finnish Plastics Recycling Ltd) is a producer organization for plastic. It was founded in order to improve the recycling of used plastic products in Finland. Most of the plastics are produced from the byproducts of oil refining. The recycling of used plastic has been executed almost from the beginning of the use of plastic but it has become business only with more common use of plastics and because of the more efficient use of raw materials. The recycled plastic needs to be well sorted and clean. There are several ways for the utilization of used plastic products: they can be used again as a product (cages, boxes) or as material (refuse sack, plastic pipe) as there are several plants in Finland that are recycling plastic. In addition, plastic can be used as energy in appropriate power plants. (Suomen uusiomuovi 2009c)

Most of the plastic packages recycled by Suomen Uusiomuovi Oy are PE-LD, PE-LLD, PE-HD films and PE-HD canisters, bottles and boxes. Recycled raw material can be used for the manufacturing of plastic tubes and films and die-casting products whereas PET bottles are used as material in textile industry. New products, like plastic sheets and straps from recycled plastics, need to be generated and the combining of plastic and fibre need to be studied. (Suomen uusiomuovi 2009d)

Producer responsibility organizations for wooden packaging

The producer organization for wooden packages is Puupakkausten Kierrätys PPK Oy. The most important product of wooden packages is a loading pallet but e.g. frame works, boxes, casks and cable reels belong this group as well. The recycled wooden material can be used as material in chipboard industry or for new wooden packages. (Puupakkausten Kierrätys (2011)

Producer responsibility organizations for metal

The producer organization for metal packaging, Mepak-Kierrätys Oy, (Mepak-Recycling Ltd) was founded in 1997 and registered with the authorities in 1998. The partners of

the organization are twelve metal packaging manufacturers, the packing industry and retail-wholesale trade organizations in Finland. Metal packaging includes food cans, paint pails, drums, crown caps, closures, aluminium trays, aerosols, steel bands and straps. Suomen Palautuspakkaus Oy represents deposit based beverage cans. Mepak-Kierrätys Oy has a contract with Kuusakoski Oy, Stena Recycling Oy and Eurajoen Romu Oy in order to ensure the re-use of the tinsplate scrap and the registered supplier gets a refund for tinsplate and aluminium packages. Mepak has also made a contract with the biggest Finnish waste company Lassila & Tikanoja Oyj to improve the metal collection. Every metal product has over 25 % recycled metal, and saving in energy is 75 - 95 % when using recycled steel instead of virgin raw material. (Mepak-Kierrätys 2011a) There are about 10000 collection points for the collection of household metal. Usually the collected material has been clean enough for re-use, since the small amount of tin is no problem. (Mepak-Kierrätys 2011b)

Producer responsibility organizations for fibre-based industrial packages

Suomen Teollisuuskuitu Oy is the producer organization which is responsible for the recovery of fibre-based industrial packaging in Finland. It was established in 1998. Among other packaging it covers wrappings and end labels for the paper industry, fibre-based wrapping used e.g. for the timber, plywood and steel industries, paper sacks and cardboard cores for rolls. (Suomen Teollisuuskuitu 2011)

Producer responsibility organizations for paper

Paperinkeräys Oy

Paperinkeräys Oy is a wholesaler and a producer organization. Companies in the Paperinkeräys Group buy recycled paper, paperboard and cardboard for raw material in the forest products industry. Collection of paper is carried out through local collection points, from residential, commercial and industrial premises, through paper recovery and waste management firms, from printing companies and from other commercial and industrial sources. (Paperinkeräys Oy 2011a) At the moment emptying of collection containers of housing companies is provided by independent collection company. For other residents there are 6700 collection points for paper and carton in Finland which are emptied by Paperinkeräys Oy. Collection points are open 24 hours per day and they are free of charge for citizens. (Paperinkeräys Oy 2011b)

Suomen Keräystuote

Suomen Keräystuote has been the producer organization for paper since 2005. It was established in 1987 by private paper collection companies and now it is the subsidiary company of Lassila & Tikanoja. The collected paper is mainly used as raw material for newspaper and sanitary tissue in domestic paper industry. (Suomen keräystuote Oy 2011)

Producer responsibility organizations for waste electric and electronic equipment (WEEE)

SER-tuottajayhteisö ry (SERTY)

The association of electric and electronic equipment manufacturers and importers, SERTY, take care of the collection and recycling of waste electric and electronic

equipment (WEEE) on behalf of its members in Finland. (SERTY 2011a) SERTY was founded in 2000 because of the changes in the hazardous waste legislation (SERTY 2011b).

Elker Oy

Elker Oy is a service company established by the producer organisations SELT Association, ICT Producer Co-operative, and FLIP Association. The above producer organisations have transferred obligations to Elker Oy. (Elker Oy 2010a) SELT Association recycles electrical and electronic equipments (Elker Oy 2010b), ICT Producer Co-operative recycles IT and telecommunications technology equipments (Elker Oy 2010c) and FLIP Association recycling lamps falling within the scope of the WEEE directive (Elker Oy 2010d) Discarded household electrical and electronic equipment are returned to consumer product collection points without fee. (Elker Oy 2010e)

The European Recycling Platform (ERP)

ERP Finland is a producer responsibility organization both for WEEE and portable batteries. ERP Finland was established in 2005 originally under the company name NERA (Association was Nordic Electronics Recycling Association), but has been working under ERP brand since 2009. In 2008 ERP Finland expanded to cover also the producer responsibility on portable batteries. (The European Recycling Platform 2011)

Kuusakoski service points are receiving all the electronic and electric devices from the household as well, for the utilization of metal, plastic and glass. Moreover, many electronic and electric devices include hazardous materials and therefore it is especially important to get them to waste electric and electronic equipment (WEEE) recycling. Recyclable items are for example TV sets, computers, DVD players, refrigerators, washing machines, ovens, phones, heaters, tools, toys, lamps and hobby equipments. (Kuusakoski recycling 2011a).

Producer responsibility organizations for end-of life vehicles

Finnish Car Recycling Ltd is producer organization, which co-ordinates the collection, treatment and recycling of scrap cars. Association of Automobile Importers in Finland owns Finnish Car Recycling. (Suomen autokierrätys 2011a)

In the recycling system the vehicle documents and registration and identification data are verified because only the owner can scrap the vehicle. The deliverer of the car gets a certificate of destruction and the vehicle is deregistered. As a pre-treatment in the recycling system the vehicle is dried, i.e. all liquids are removed. Tires, the battery and catalyser are removed and components with a danger of an explosion e.g. airbags, are removed or deactivated. After that, the vehicles are crushed and sorted into three different categories: magnetic steel (raw-material for the steel industry), non-ferrous residue of various metals (processed further into the raw-materials of the metal industry) and light components (recovered as energy or landfilled) (Suomen autokierrätys 2011b).

Producer responsibility organizations for batteries and accumulators

Recser Oy

Recser Oy is producer organization for portable batteries and accumulators. Retail outlets that are selling batteries and accumulators receive used portable batteries and accumulators from consumers. (Recser 2008).

Akkukierrätys Pb Oy

Akkukierrätys Pb Oy producer organization for the lead acid battery used e.g. in cars. Organization was established by importers Exide Technologies Oy, EnerSys Europe Oy, Koivunen Oy and AkroPower Oy and now over 80 importers of lead acid batteries are joined in Akkukierrätys Pb Oy. Collection of the lead acid battery has been organized in cooperation with Kuusakoski Oy, Lassila & Tikanoja Oyj and Stena Recycling Oy and it has been successful. There are over 600 collection points all over Finland. Materials of batteries are recovered in foundry and they are used again when manufacturing new batteries. (Akkukierrätys 2008)

Used tires

Suomen Rengaskierrätys (Finnish Tyre Recycling Ltd) is responsible for the recycling of used vehicle tires in Finland. Company started tire recycling in 1996 and is owned by major Finnish tire manufacturers and importers. (Rengaskierrätys Oy 2011) Pohjoinen rengaskierrätys (North Re-Tyre Oy) is another producer organization for used tires (North Re-Tyre Oy 2010).

Kuusakoski and Suomen Rengaskierrätys take care of the recycling of the used tires in Finland. Annually about 40 000 tonnes of tires is recycled in Finland and the utilization percentage is about 95%, the average percentage of this utilization is ca 60% in Europe. The targets of utilization of crushed tires are elastic groundwork for e.g. riding and sports fields. All the service points of Kuusakoski and tire selling companies receive the tires with and without the band for free, after which they are recycled. (Kuusakoski recycling 2011b) The collection rate of tires was 90% already in 1999. (Melanen et al. 2002, 11)

Appendix 3. Surface containers and deep containers



20. Surface collection containers. a) L&T® Jäkki -jäteastia 400-1000 L, b) L&T® Jäkki -jäteastia 120-360 L and c) L&T® BioJäkki -jäteastia 140 L for bio-waste. (Lassila-Tikanoja 2012)

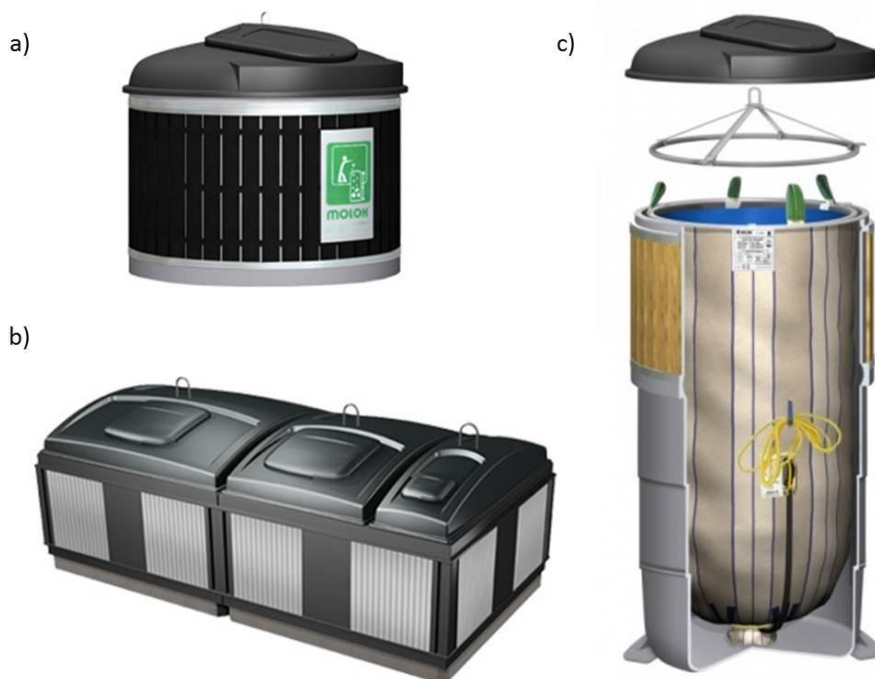

21. Molok deep collection containers. a) Basic container, b) MolokDomino and c) Working principles of Molok deep collection containers. (Molok ltd. 2009)

Appendix 4. Amounts of wastes under producer responsibility

Table 28. Amounts of wastes under producer responsibility collected in 2006 (Ympäristöministeriö 2010a)

Waste sector	Producer organization	Collected waste (tonnes/a)
WEEE producer organization		38 940
	Flip Ry	946
	ICT-tuottajaosuuskunta-TY	5 336
	Pohjoismaiden Elektroniikkakierrätysyhdistys Ry NERA	11 823
	SELT Ry	546
	Ser-Tuottajayhteisö ry	20 289
Vehicle producer organization		14 183
	Suomen autokierrätys Oy	14 183
	Suomen matkailuautokierrätys	0
Tire producer organization		45 535
	Suomen rengaskierrätys Oy	44 698
	North Re-Tyre Oy	837
Paper producer organization		355 931
	Paperinkeräys Oy	301 376
	Suomen Keräystuote Oy	54 555
Packagings*		
	Suomen Aaltopahviihdistys Ry, Suomen Teollisuuskuitu Oy, Suomen kuluttajakuitu Ry, Suomen NP-Kierrätys Oy	225 000
	Suomen Uusiomuovi Oy	15 400
	Suomen Keräyslasiyhdistys Ry	49 600
	Mepak-Kierrätys Oy and Suomen Palautuspakkaus Oy	26 400
	Puupakkausten Kierrätys PPK Oy	15 800

*Amounts of packaging waste include also other packaging waste than collected by using producer responsibility organization system

Appendix 5. Costs of the establishment of the new collection point network.

(Ympäristöministeriö 2010b)

Table 29. Estimate of the amount of waste material collected

Material	Amount of material m ³ /week/area			
	500 inhabitants	1000 inhabitants	2000 inhabitants	5000 inhabitants
Glass	0,058	0,115	0,231	0,577
Metal	0,011	0,022	0,044	0,111
Paperboard	1,346	2,692	5,385	13,462
Plastic	0,096	0,192	0,385	0,962

Table 30. Estimate of the number of emptying times

Material	Emptying times per year				
	Less than 500 inhabitants	500 - 1000 inhabitants	1000 - 2000 inhabitants	2000 - 5000 inhabitants	Over 5000 inhabitants
Glass	6	6	6	12	12
Metal	8	8	8	8	8
Paperboard	26	26	52	52	52
Plastic	8	8	8	8	8

Table 31. Type on waste container based on the handling method of the container

Material	Emptying method				
	Less than 500 inhabitants	500 - 1000 inhabitants	1000 - 2000 inhabitants	2000 - 5000 inhabitants	Over 5000 inhabitants
Glass	Machine	Machine	Machine	Machine	Machine
Metal	Manual	Manual	Machine	Machine	Machine
Paperboard	Machine	Machine	Machine	Machine	Machine
Plastic	Manual	Manual	Machine	Machine	Machine

Table 32. The purchase price for the waste containers

Material	The purchase price for the waste containers (euros / container)				
	Less than 500 inhabitants	500 - 1000 inhabitants	1000 - 2000 inhabitants	2000 - 5000 inhabitants	Over 5000 inhabitants
Glass	1 000	1 000	1 000	1 000	1 000
Metal	245	245	245	1 000	1 000
Paperboard	1 000	1 000	1 700	1 700	1 700
Plastic	245	245	245	1 700	1 700

Table 33. The emptying costs of the waste containers

Material	The emptying costs the waste containers (euros / emptying)				
	Less than 500 inhabitants	500 - 1000 inhabitants	1000 - 2000 inhabitants	2000 - 5000 inhabitants	Over 5000 inhabitants
Glass	20	20	20	20	20
Metal	5	5	25	25	25
Paperboard	30	30	30	30	30
Plastic	5	5	15	15	15

Table 34. The number of collection points in different network options (dense, standard, sparse)

Network	The number of collection points					Total
	Less than 500 inhabitants	500 - 1000 inhabitants	1000 - 2000 inhabitants	2000 - 5000 inhabitants	Over 5000 inhabitants	
Standard	242	167	125	109	729	1 372
Dense	242	167	125	139	1 877	2 550
Sparse	12	39	125	109	729	1 014

Table 35. The numbers of the containers

Material	Number of waste container				
	Less than 500 inhabitants	500 - 1000 inhabitants	1000 - 2000 inhabitants	2000 - 5000 inhabitants	Over 5000 inhabitants
Glass	1	1	1	1,5	2
Metal	1	1	1	1	1
Paperboard	1	1	1	1,5	2
Plastic	1	1	1	1,5	2

Table 36. The total investment for the collection network

Network	Building (euros)	Containers (euros)	Investment, total (euros)
Standard	6 446 000	9 610 000	16 056 000
Dense	13 268 000	21 089 000	34 357 000
Sparse	5 301 000	8 622 000	13 923 000

Table 37. Investments for the collection points.

Material	Standard (euros)	Dense (euros)	Sparse (euros)
Glass	3 397 000	7 086 000	2 833 000
Metal	1 759 000	3 616 000	1 465 000
Paperboard	6 206 000	13 257 000	5 378 000
Plastic	4 694 000	10 397 000	4 246 000
Total	16 056 000	34 356 000	13 922 000
Average cost/point	11 700	13 500	13 700

Table 38. The annual costs per collection point

Material	Standard (euros/year/point)	Dense (euros/year/point)	Sparse (euros/year/point)
Glass	880	1 010	1 020
Metal	460	520	530
Paperboard	3 040	3 610	3 680
Plastic	910	1 070	1 110

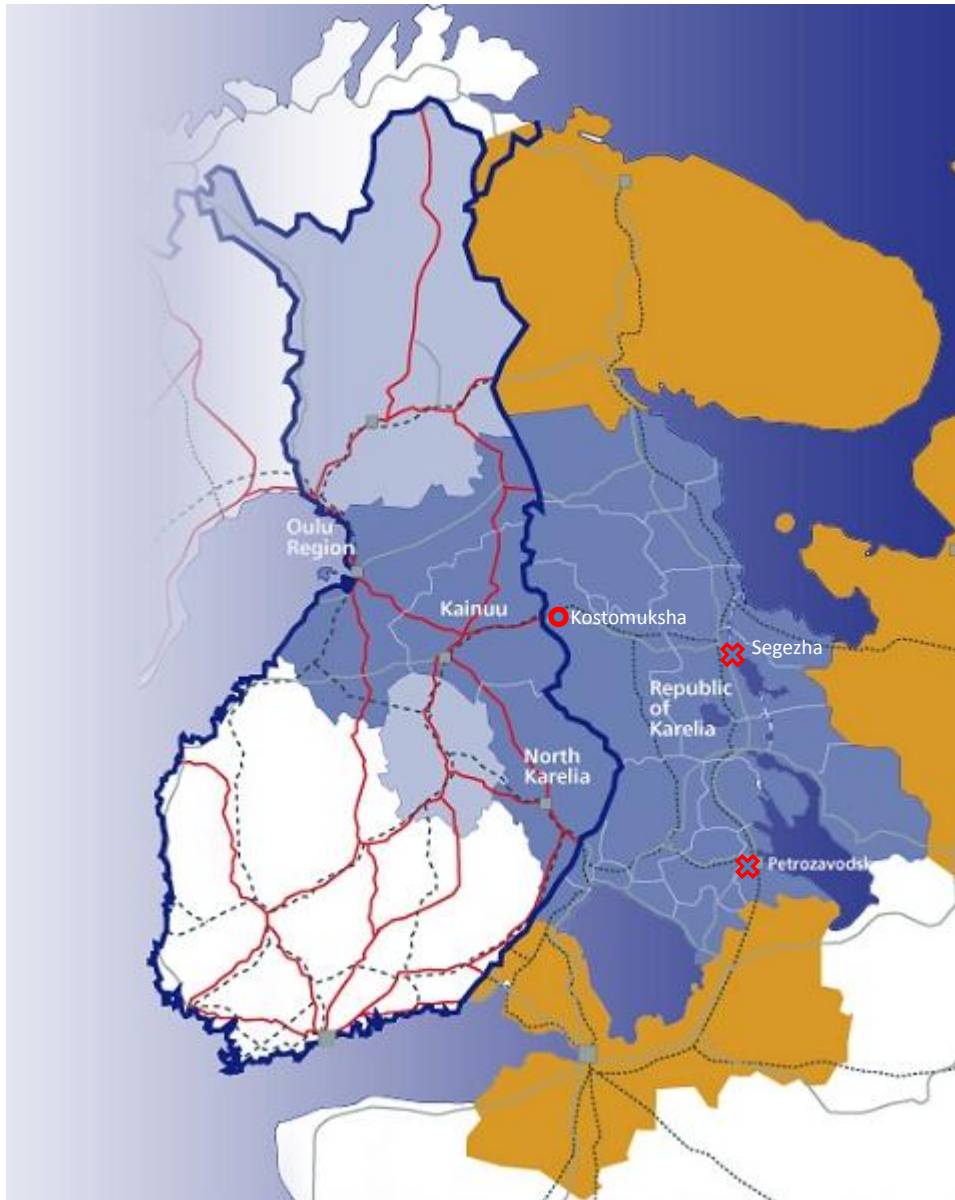
Appendix 6. Map of Karelia and Finland.

Figure 22. Map of Karelia and Finland. Circle shows the location of the city of Kostomuksha, crosses show the location of the transfer station and utilization facilities, Segezha and Petrozavodsk. (Euregio Karelia 2010)